

MASTER

fischertechnik  DESIGNED BY *Klaus Fischer*



BAUANLEITUNG
HANDLEIDING

ASSEMBLY MANUAL
INSTRUCCIÓN DE MONTAGE

MODE D'EMPLOI
ISTRUZIONE AL MONTAGGIO



MOTOR MASTER

fischertechnik  DESIGNED BY *Klaus Fischer*

Montagen
Mountings
Montages

Montage's
Montajes
Assemblaggio

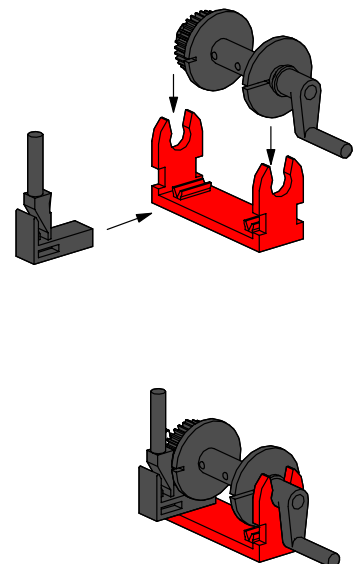
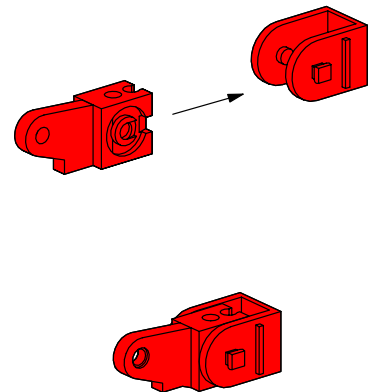
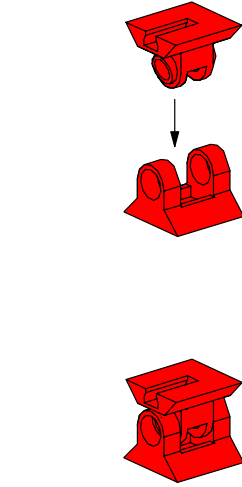
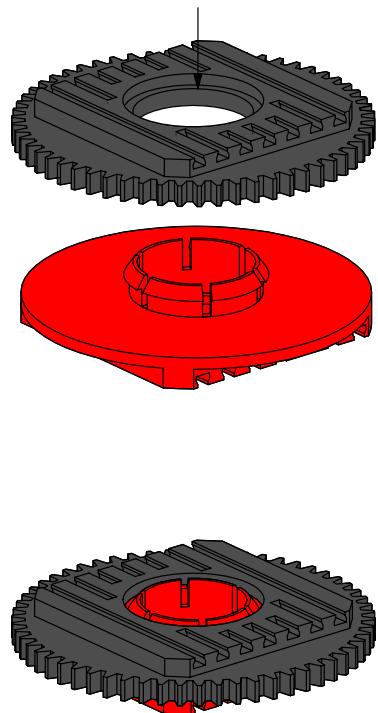
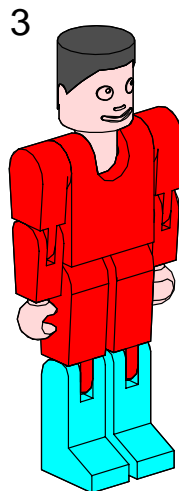
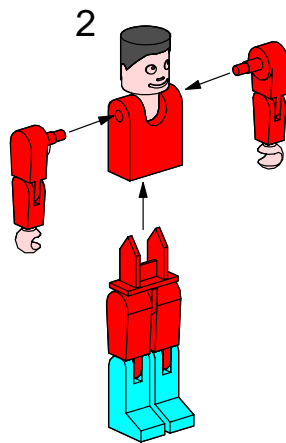
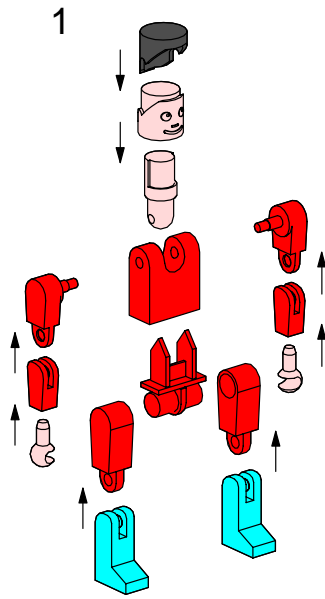
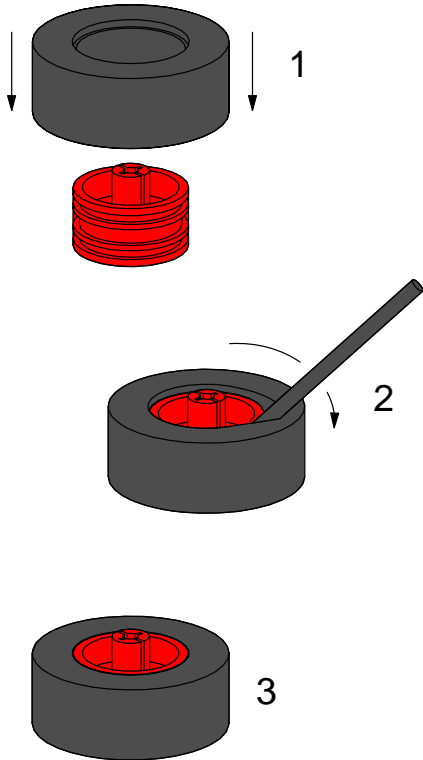

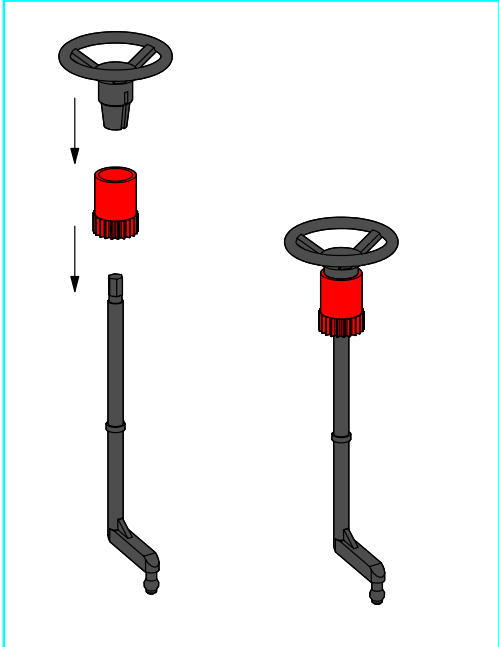
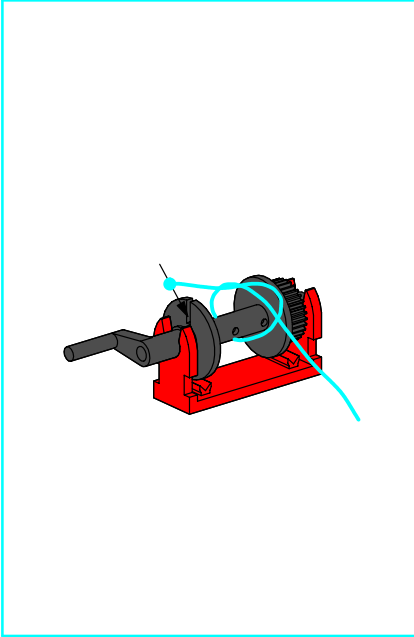
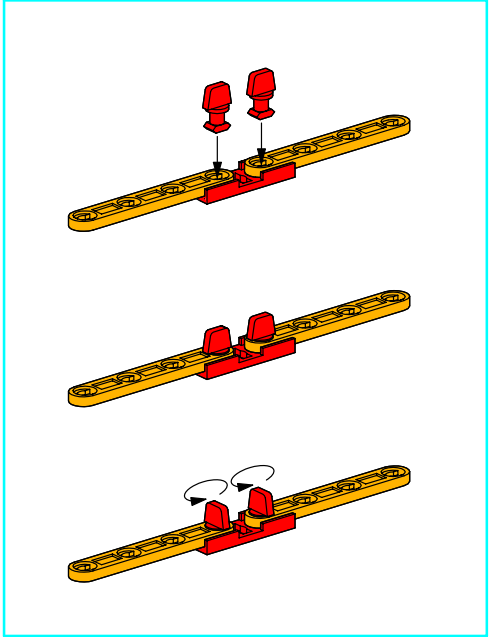
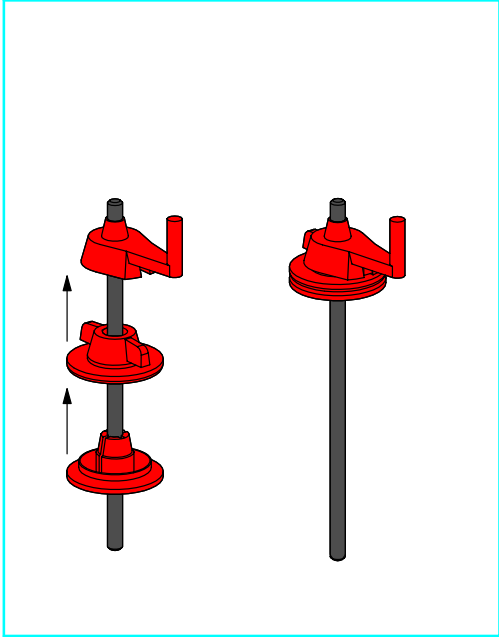
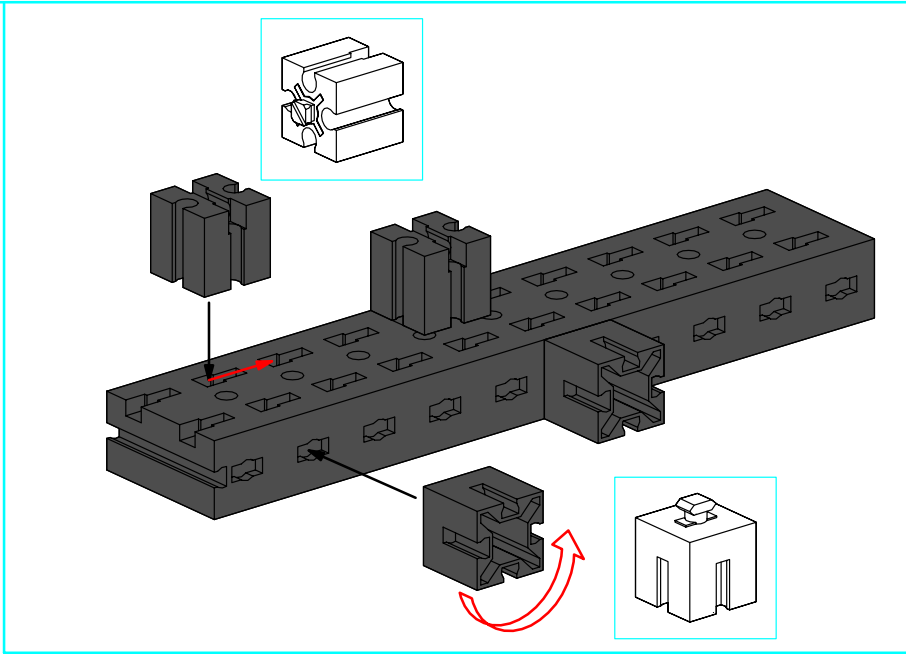
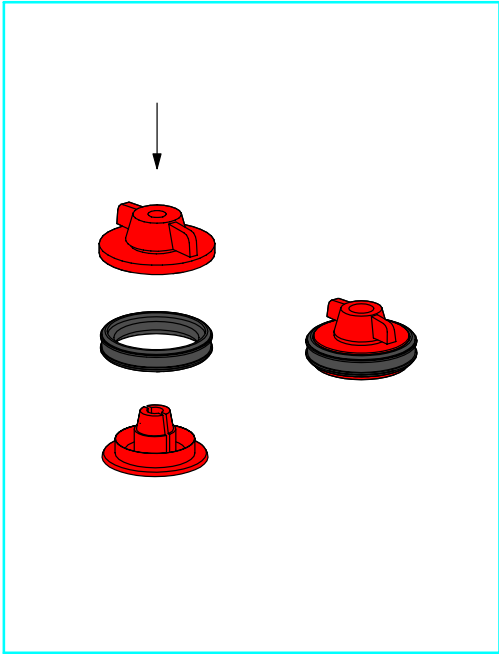

Alle Einzelteile, insbesondere bewegliche Teile sind falls notwendig zu warten und zu reinigen.
 All components, especially moving parts, should be maintained and cleaned as necessary.
 Toutes les pièces détachées et en particulier les pièces mobiles, sont, si nécessaire, à entretenir et à nettoyer.
 Alle onderdelen, vooral de bewegende delen, kunnen, indien noodzakelijk, onderhouden en gereinigd worden.
 Es necesario limpiar y mantener en buen estado todas las diferentes piezas – especialmente las piezas móviles.
 Provvedere all'occorrenza alla manutenzione e alla pulizia di tutti i particolari, specialmente le parti mobili.

1

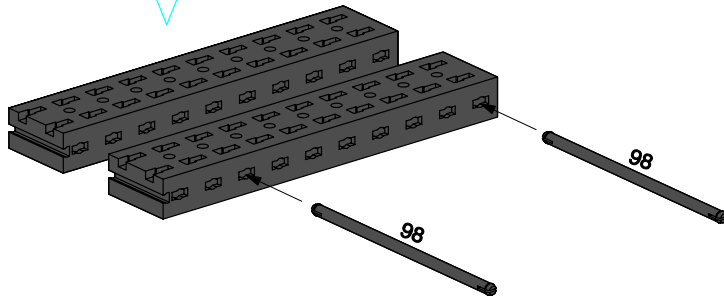
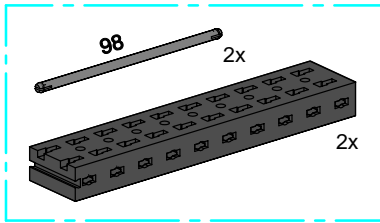

2

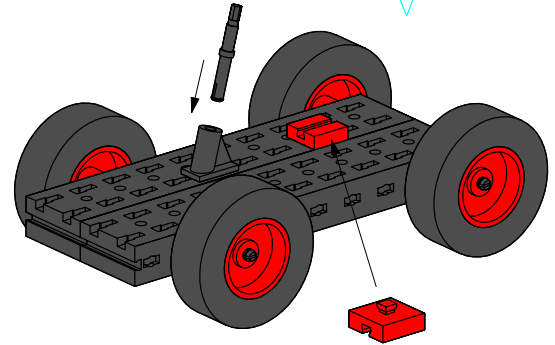
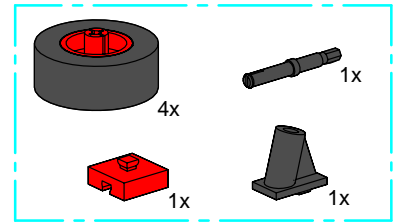

3

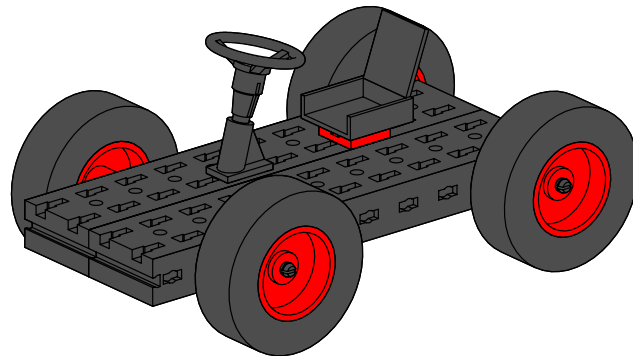
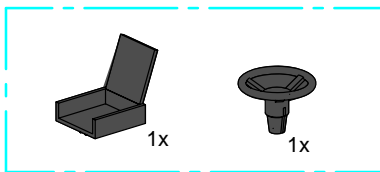

4

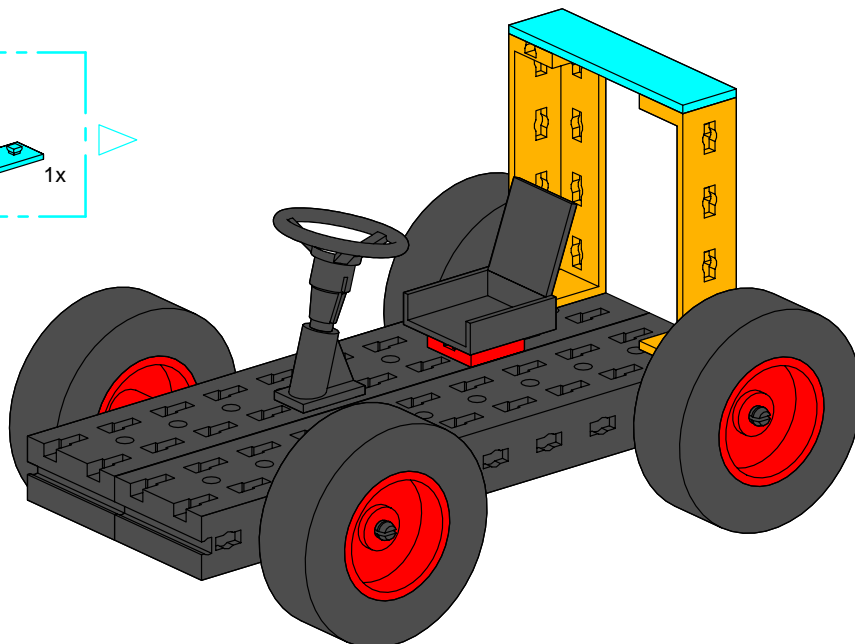
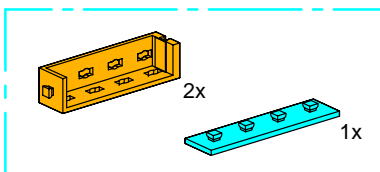

98mm

Flugzeuge
Planes
Avions

Vliegtuigen
Aviones
Aereoplani

1

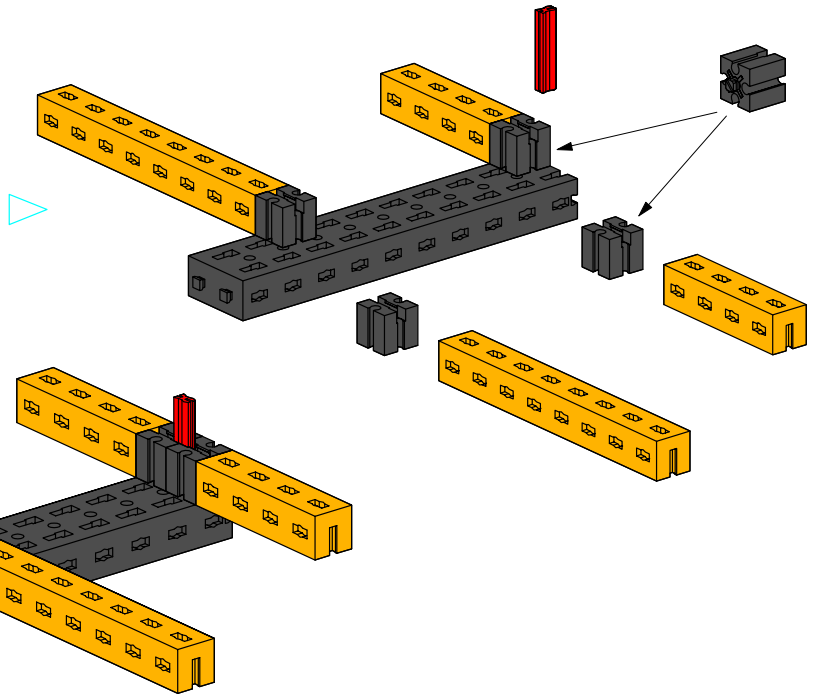
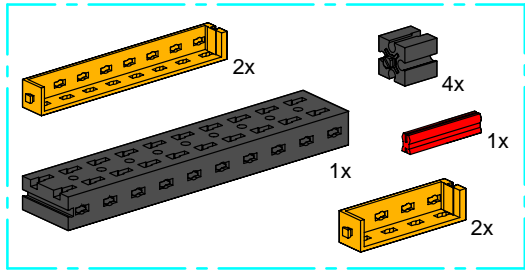

2

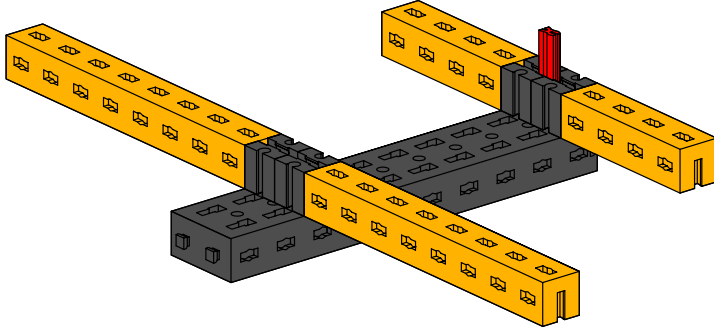

1

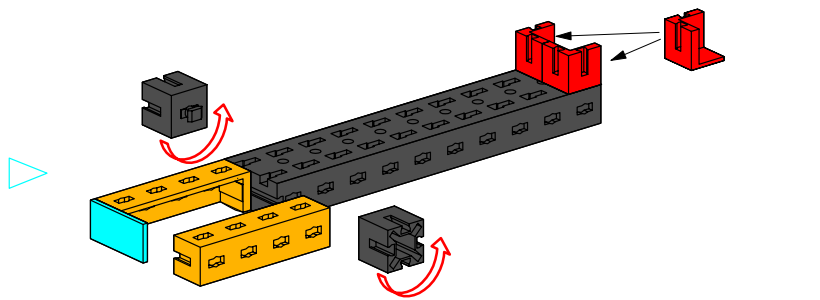
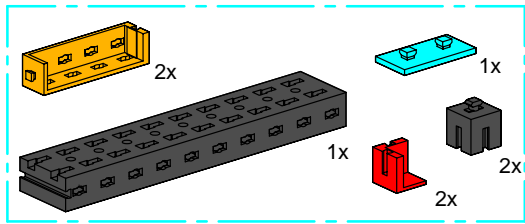

2

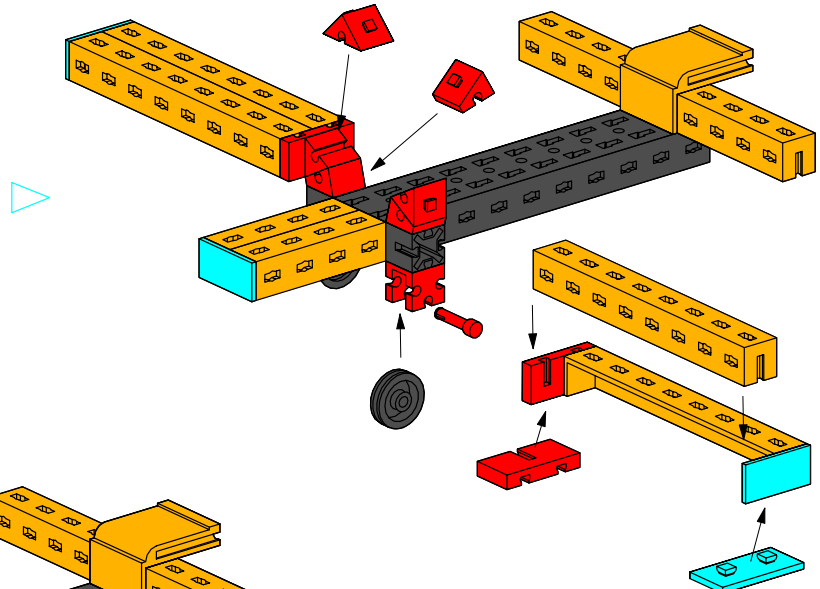
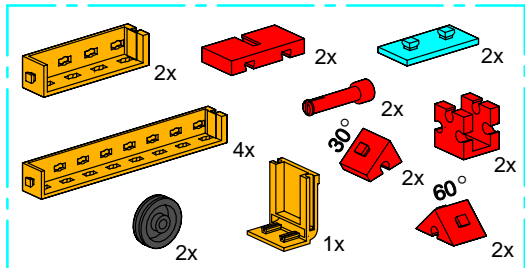

3

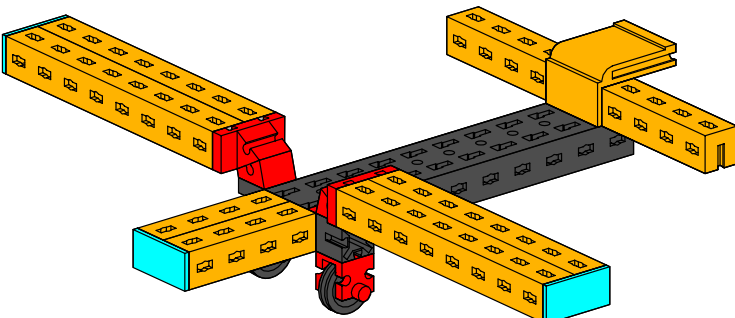

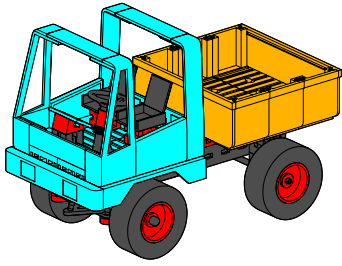

Lastwagen
Truck
Camion

Vrachtwagen
Camión
Camion

1

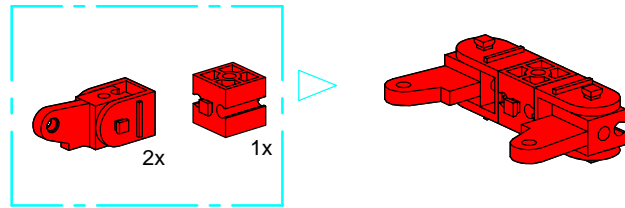

2

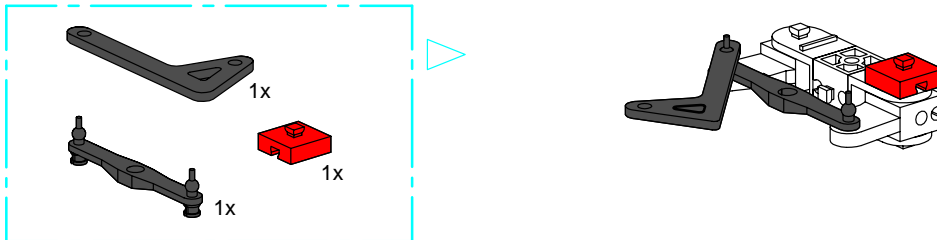

3

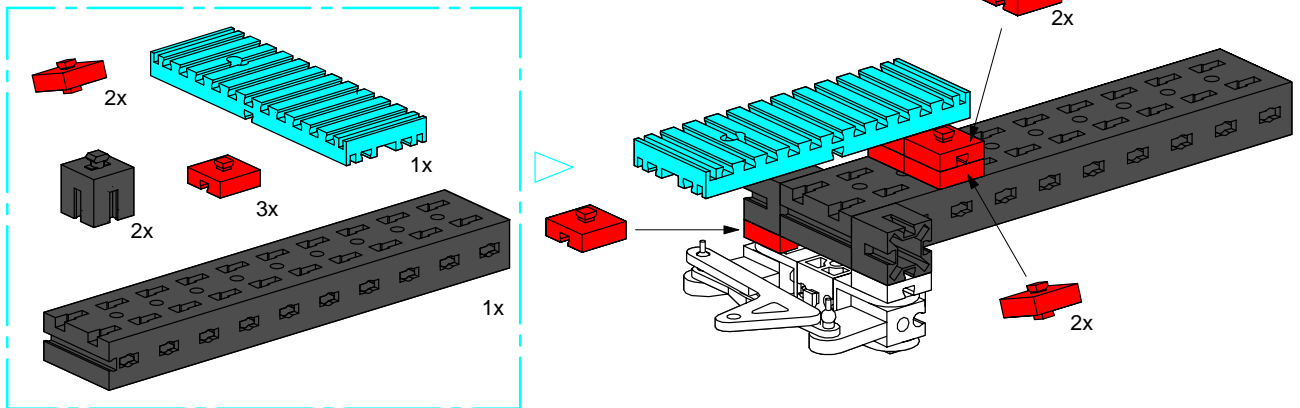

4

