

# Mobile Robots II

**6**  
models

  
COMPUTING

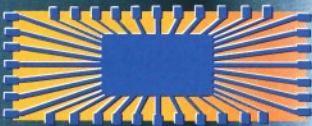
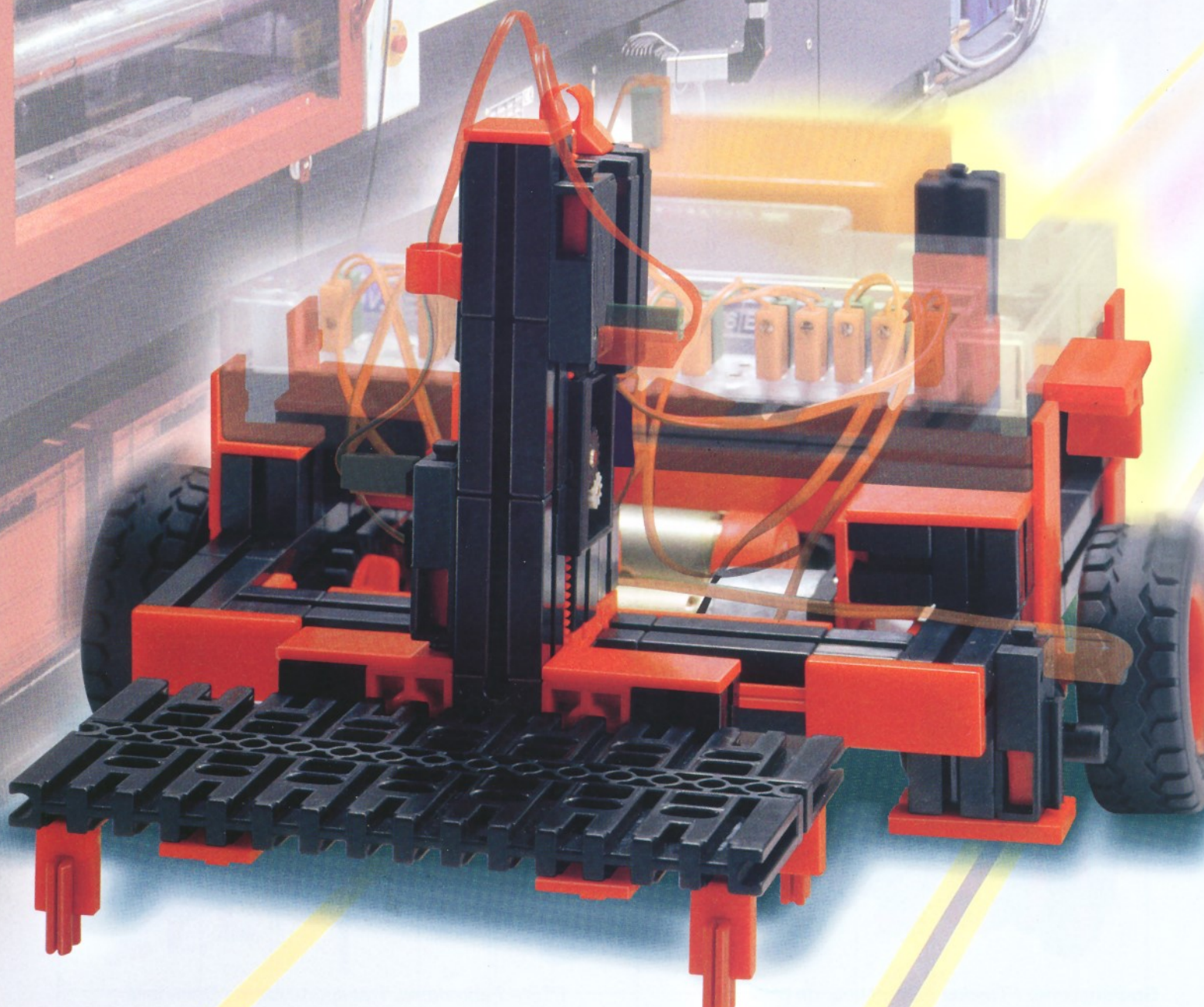

**fischertechnik**<sup>®</sup>









**Montagehilfen und Hinweise**  
**Assembly aids and instructions**  
**Aides de montage et instructions**

**Montagehulpmiddelen en aanwijzingen**  
**Ayudas de montaje e instrucciones**  
**Montagens e indicações**

Kabel und Stecker  
Plugs and cables  
Fiches et des câbles

**1**

4 x 15 cm  
8 x 23 cm

0 3cm

**2**

3cm 3cm

Stekkers en cables  
Enchufes en cables  
Cabos e contatos

**3**

4mm

**4**

4 x 15 cm  
8 x 23 cm

**1**

9 V ...

**2**

2x

**1**

**2**

**1**

**2**

4x

Alle elektrischen Bauteile (Sensoren, Motoren, Lampen) dürfen ausschließlich an Stromversorgungen von fischertechnik angeschlossen werden (z.B. Energy Set Art.-Nr. 30182; Accu Set Art.-Nr. 34969).  
 No electrical components (sensors, motors and lamps) are to be connected to any other power supply than that provided by fischertechnik (e.g. Energy Set, product no. 30182, Accumulator Set, product no. 34969).  
 Tous les composants électriques (Capteurs, moteurs, lampes) ne doivent être branchés aux alimentations électriques uniquement que par la société Fischertechnik (par exemple: Set énergie Art.-Nr. 30182, Accu Set art.-Nr. 34969).  
 Alle elektrische componenten (sensoren motoren, lampen) mogen uitsluitend op stroomvoorzieningen van fischertechnik worden aangesloten. (bijv. Energy Set art.nr. 30182, Accu Set art.nr. 34969).  
 Todos los componentes eléctricos (sensores, motores, luces) deben conectarse a la alimentación de corriente de la técnica Fischer exclusivamente (p.ej. Energy Set Art.-Nº. 30182, Accu Set Art.-Nº. 34969).  
 Todas as peças componentes elétricas (sensores, motores, lâmpadas) só podem ser exclusivamente conectadas em abastecimentos de corrente da Fischertechnik (p.ex. Energy Set Nº de prod. 30182, Accu Set Nº de prod. 34969).

Alle Einzelteile, insbesondere bewegliche Teile sind falls notwendig zu warten und zu reinigen.  
 All components, especially moving parts, should be maintained and cleaned as necessary.  
 Toutes les pièces détachées et en particulier les pièces mobiles, sont, si nécessaire, à entretenir et à nettoyer.

**Achtung**  
 Verletzungsgefahr an Bauteilen mit funktionsbedingten scharfen Kanten und Spitzen!  
**Caution**  
 Be careful not to hurt yourself on components with sharp or pointed edges!  
**Attention**  
 Risque de blessure sur les éléments comportant des arêtes et o pointes vives indispensables au bon fonctionnement!

Alle onderdelen, vooral de bewegende delen, kunnen, indien noodzakelijk, onderhouden en gereinigd worden.  
 Es necesario limpiar y mantener en buen estado todas las diferentes piezas – especialmente las piezas móviles.  
 Caso necessário, todas as peças individuais, especialmente peças móveis, tem que ser submetidas à manutenção e ser limpas.

**Let op**  
 U kunt zich bezeren aan bouwstenen met scherpe randen of punten!  
**Attenzione**  
 Esiste il pericolo di lesione con i pezzi di costruzione che hanno bordi e punte spigolosi necessari per la funzionalità del pezzo!  
**Atenção**  
 Perigo de ferimentos em peças componentes com cantos vivos e pontas obrigatórios para o funcionamento !

**Montagehilfen und Hinweise**  
**Assembly aids and instructions**  
**Aides de montage et instructions**

**Montagehulpmiddelen en aanwijzingen**  
**Ayudas de montaje e instrucciones**  
**Montagens e indicações**

Fototransistor  
 Phototransistor  
 Phototransistor

Fototransistor  
 Fototransistores  
 Fototransistor

Achtung: Beim Anschluß auf richtige Polung achten. Rot = +  
 Caution: Make sure the terminals are connected correctly. Red = +  
 Attention: lors du raccordement, veiller à ce que la polarisation soit exacte, rouge = +  
 Pas op: let bij het aansluiten op de juiste polariteit, rood = +  
 Atención: al conectar, procurar que los polos estén correctamente colocados, roja = +  
 Atenção: Por ocasião da conexão atentar para a polaridade correta. Vermelho = +



9V ...

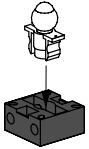

9V ... / 0,15 A

Linsenlampe  
 Lens tip lamp  
 Ampoule lentille  
 Lenslampje  
 Lampada lenticolare  
 Lâmpada de formato lenticular

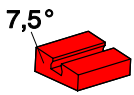
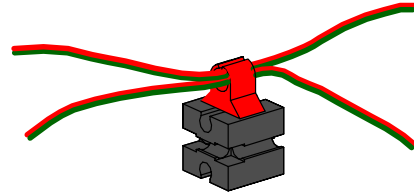

7,5°

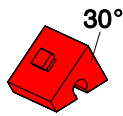

30°

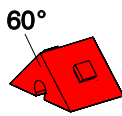

60°



7.5

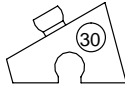

30

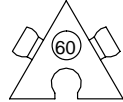

60

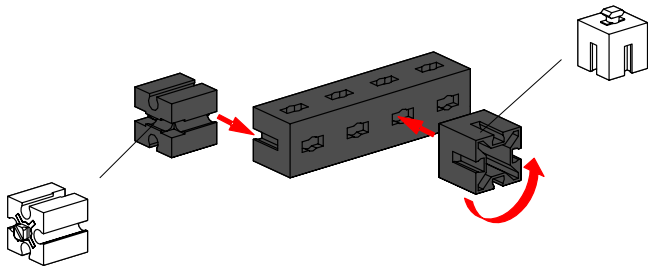
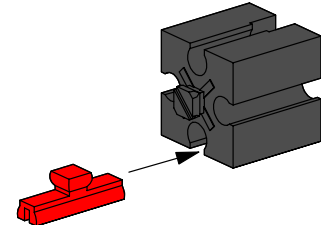
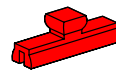
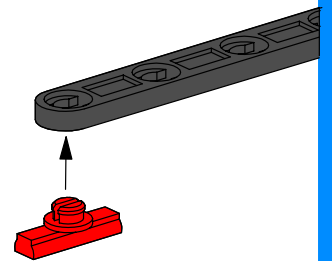
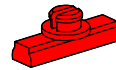

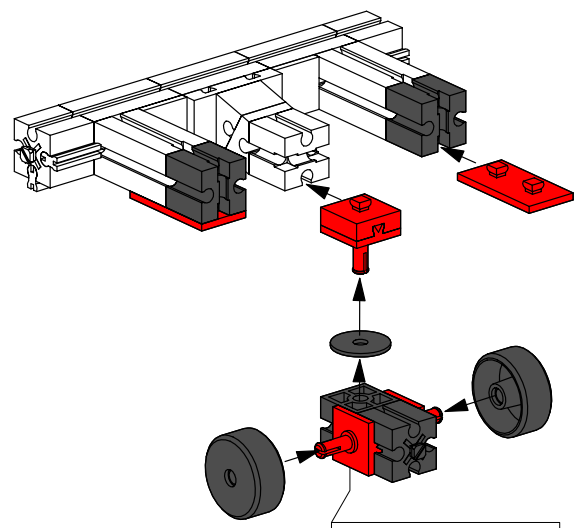
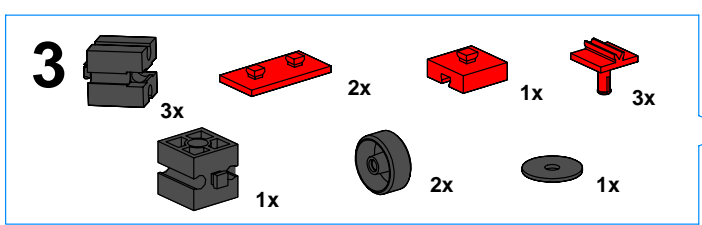
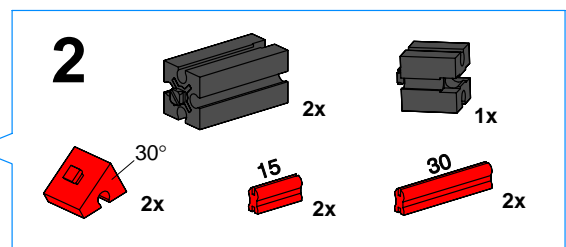
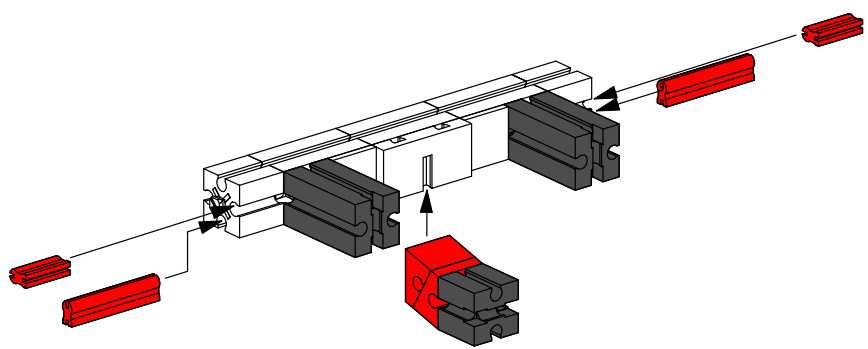
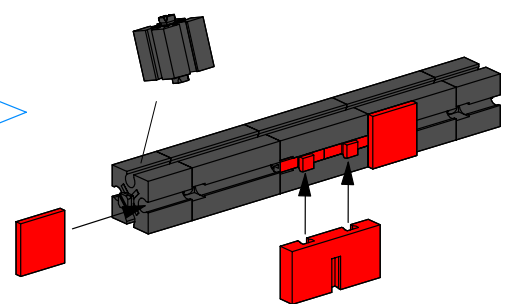
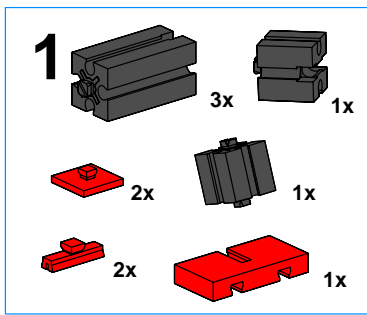
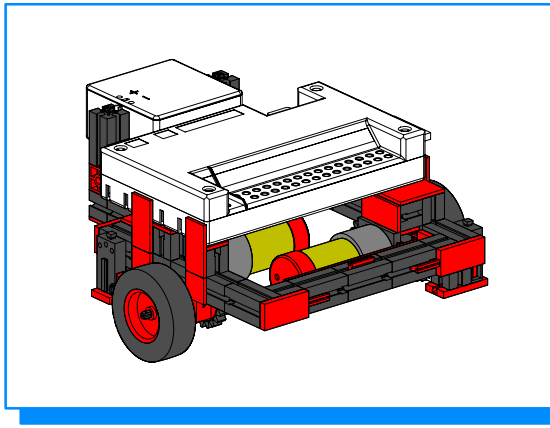

**Basismodell  
Basic Model  
Maquette de base**

**Basismodel  
Modelo básico  
Modelo básico**



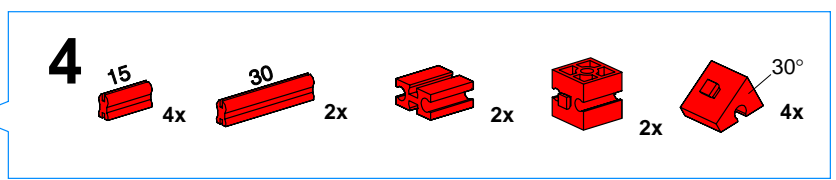
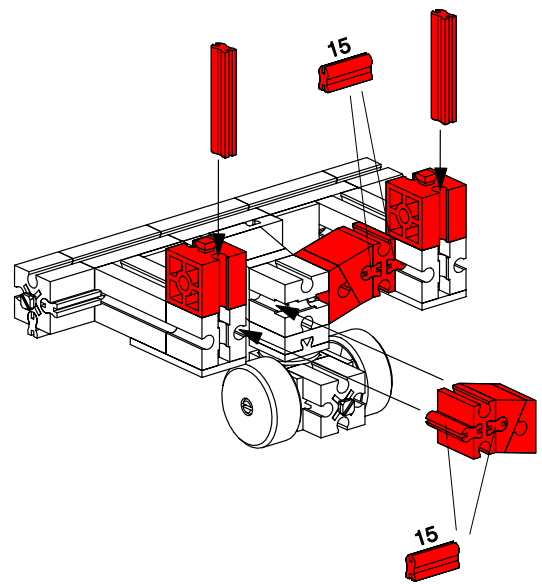

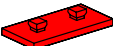
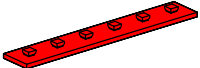
**Große Bohrung  
Large drilling  
Alésage large  
Grote boring  
Perforación grande  
Orificio grande**



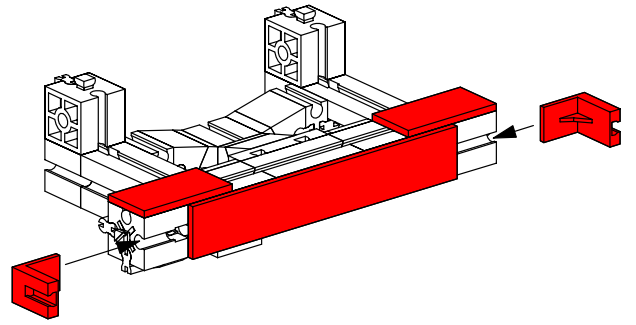
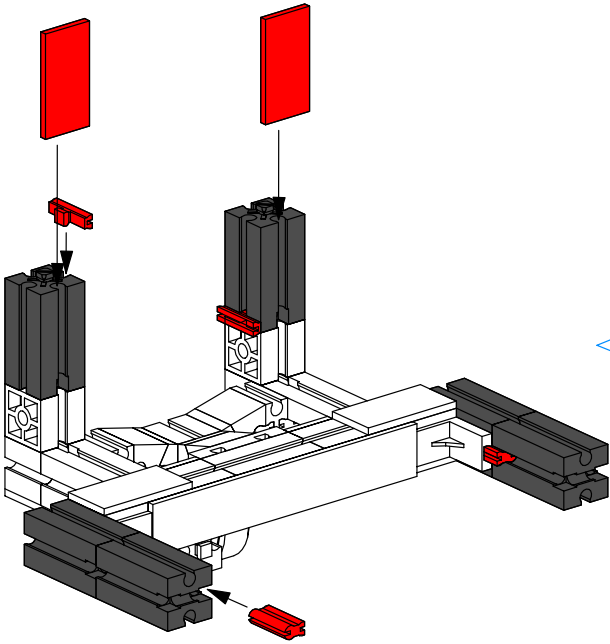

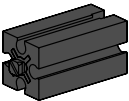

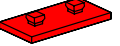

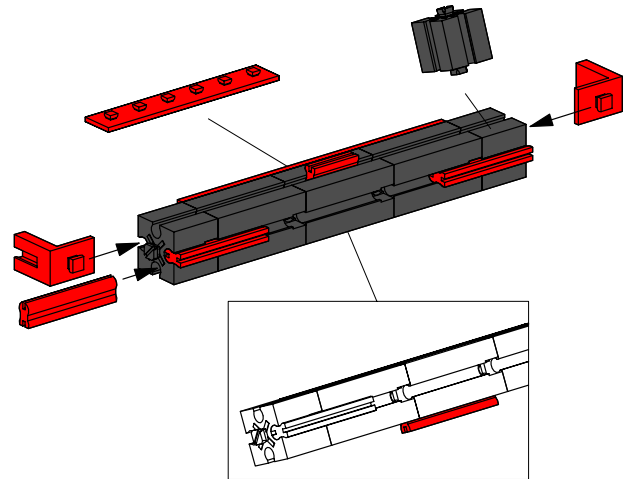
**5**  2x  1x  2x

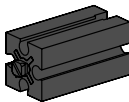



**6**  6x  2x  2x  2x



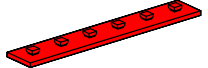

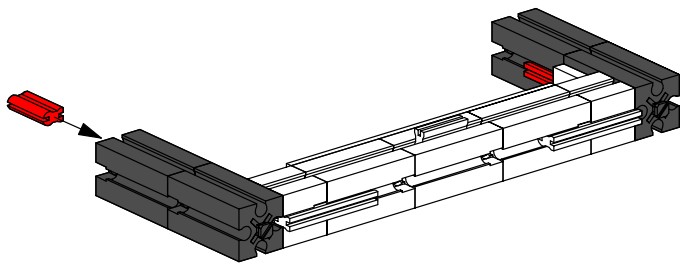
**7**  3x  1x  1x  2x

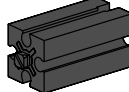

 1x  3x  1x

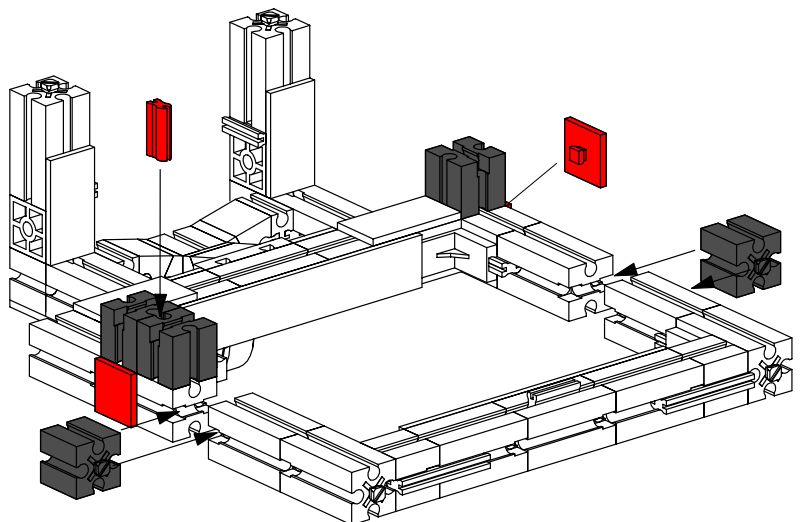

**8**  4x  1x



**9**  3x  2x

 1x  2x



























































