

RC CAR SET

fischertechnik 

ADVANCED

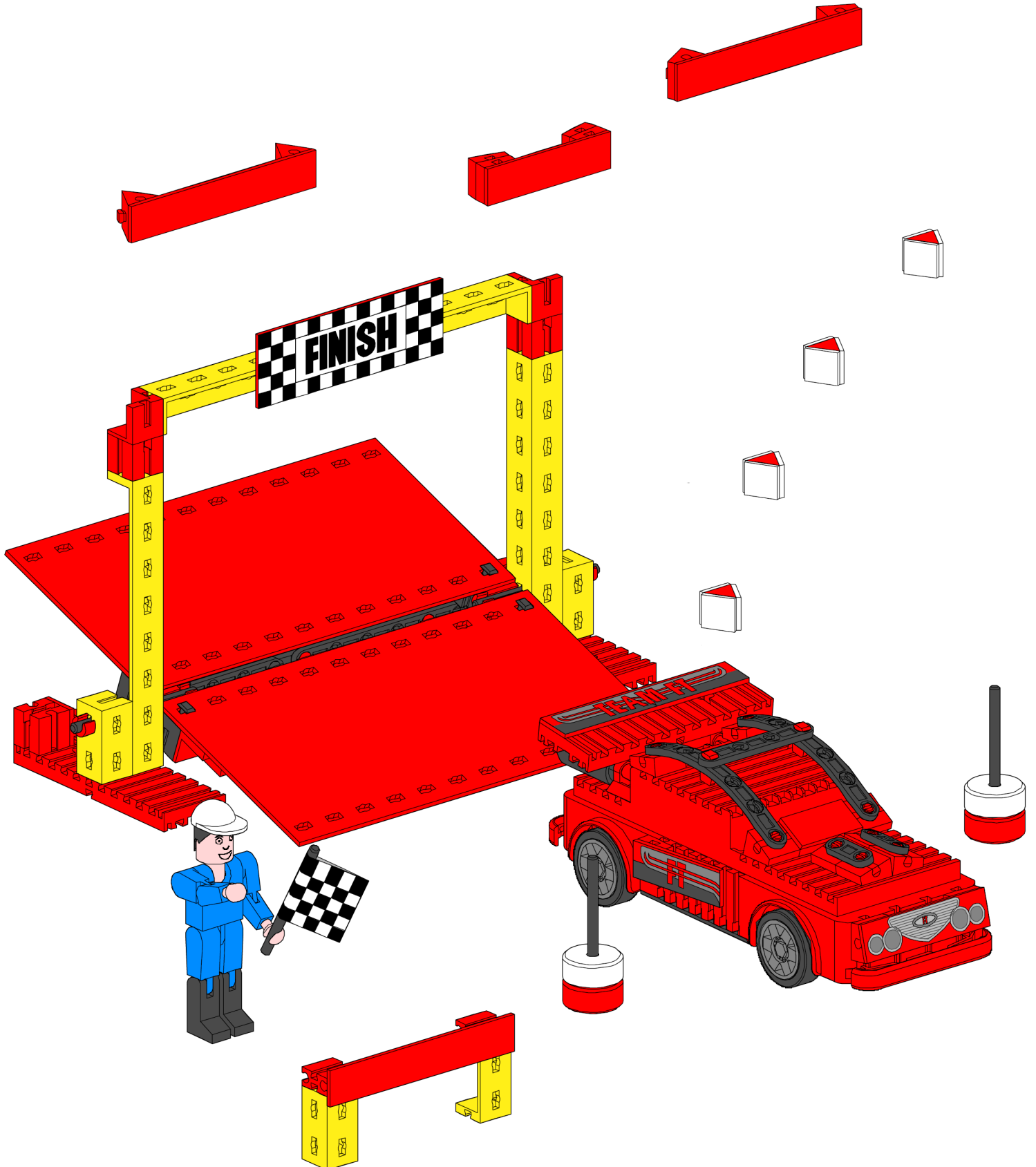

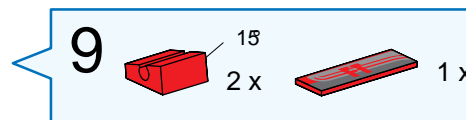
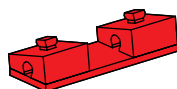
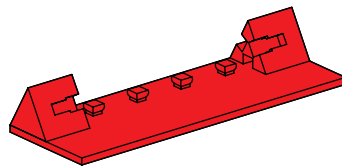
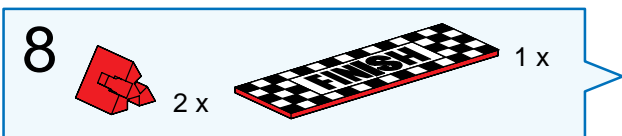
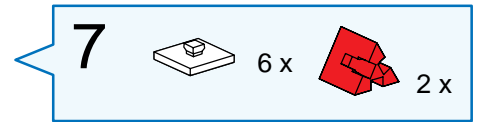
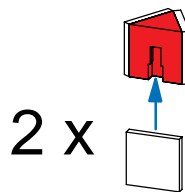
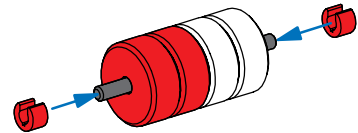
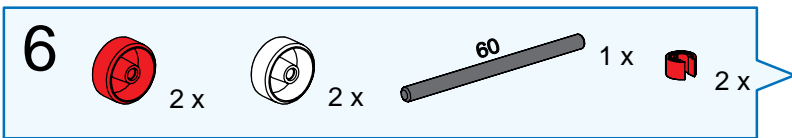
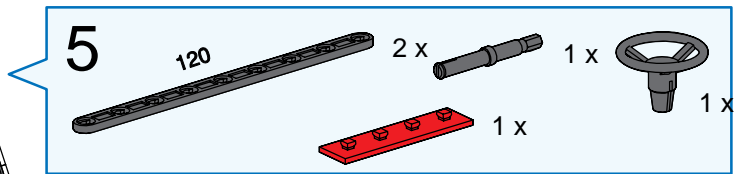
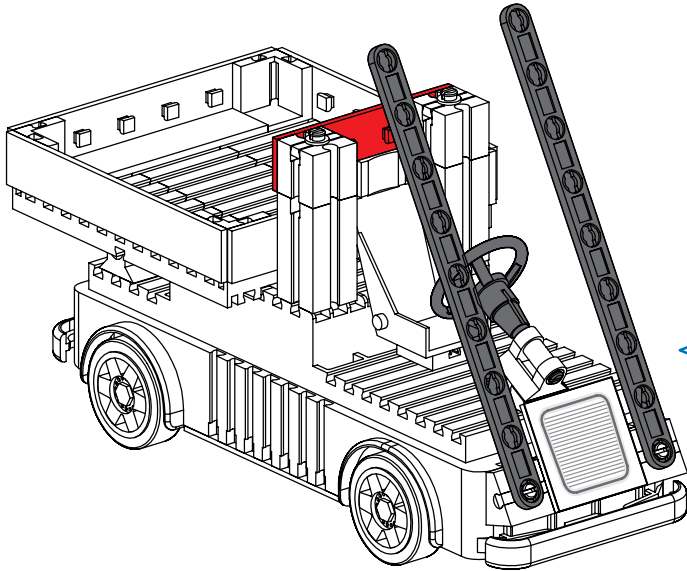
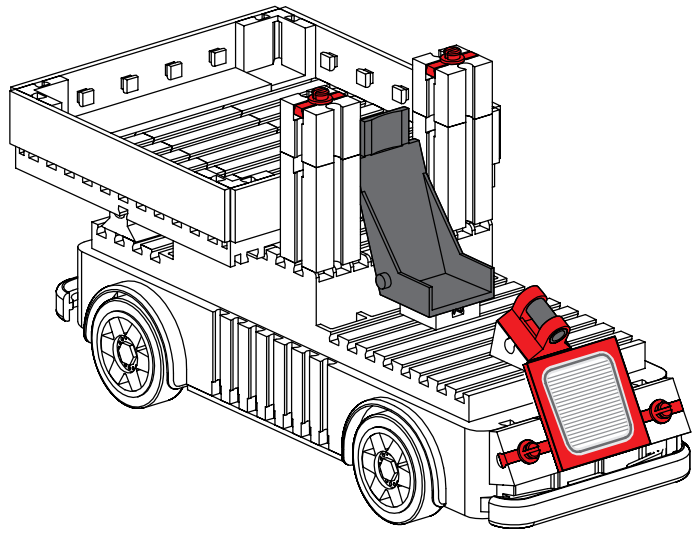
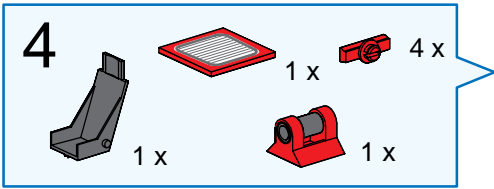

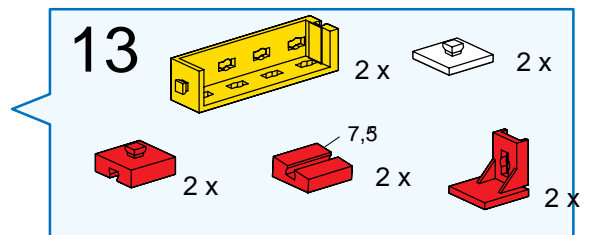
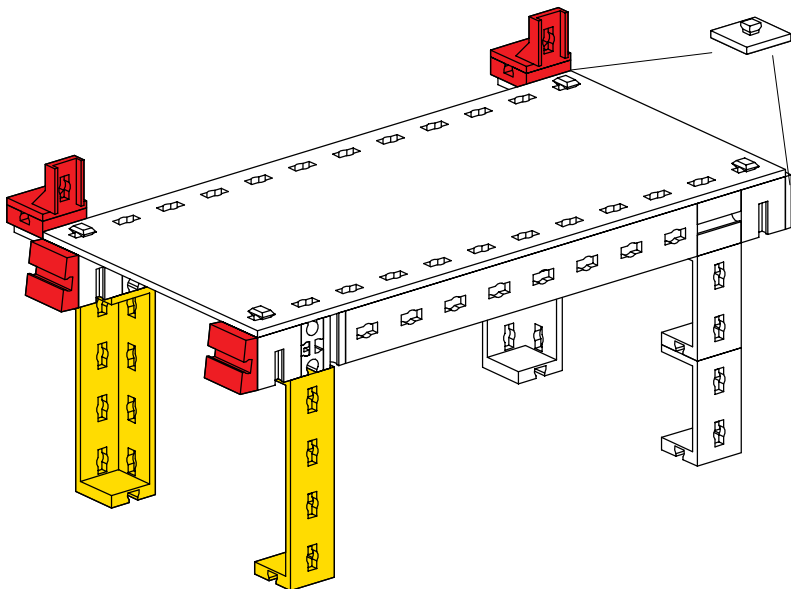
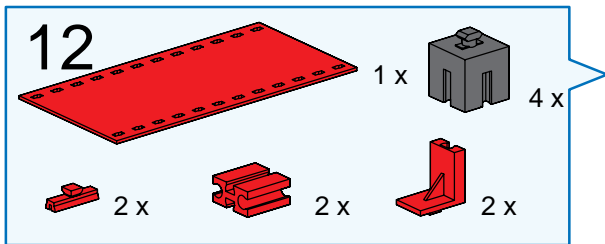
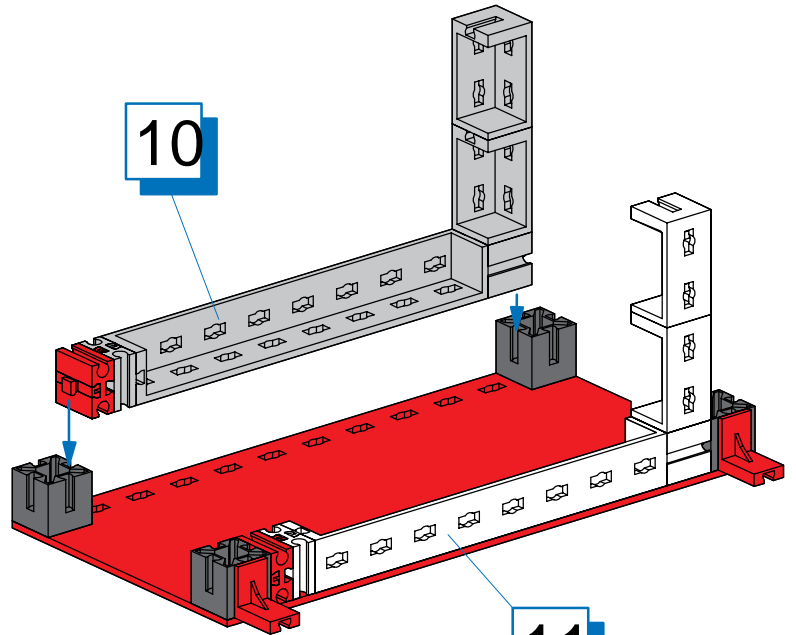
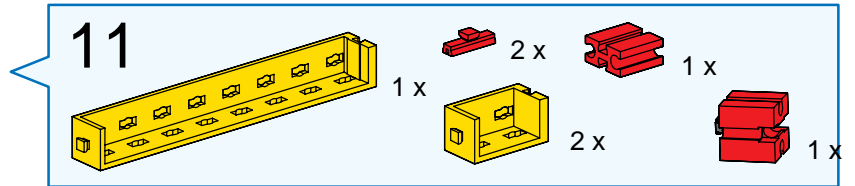
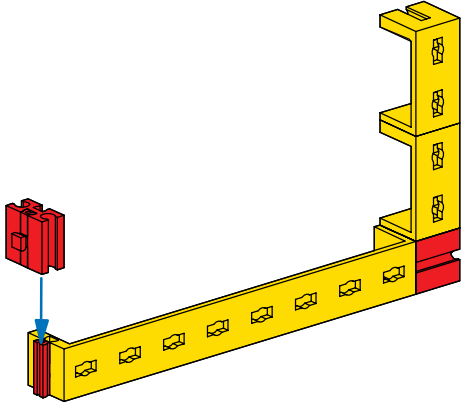
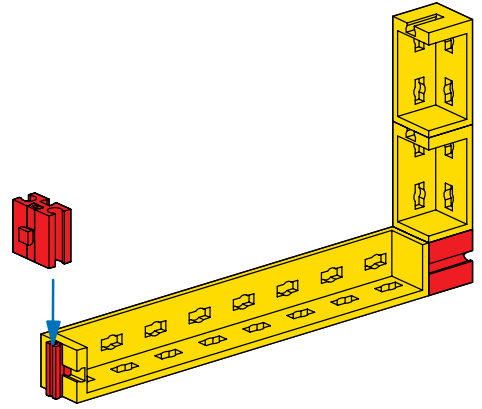
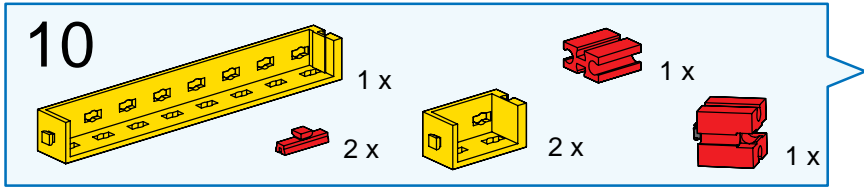

14

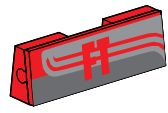
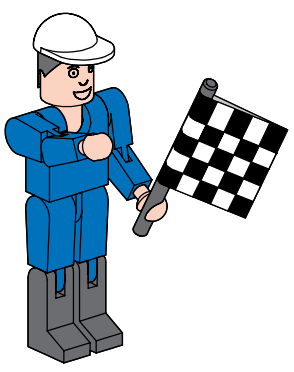
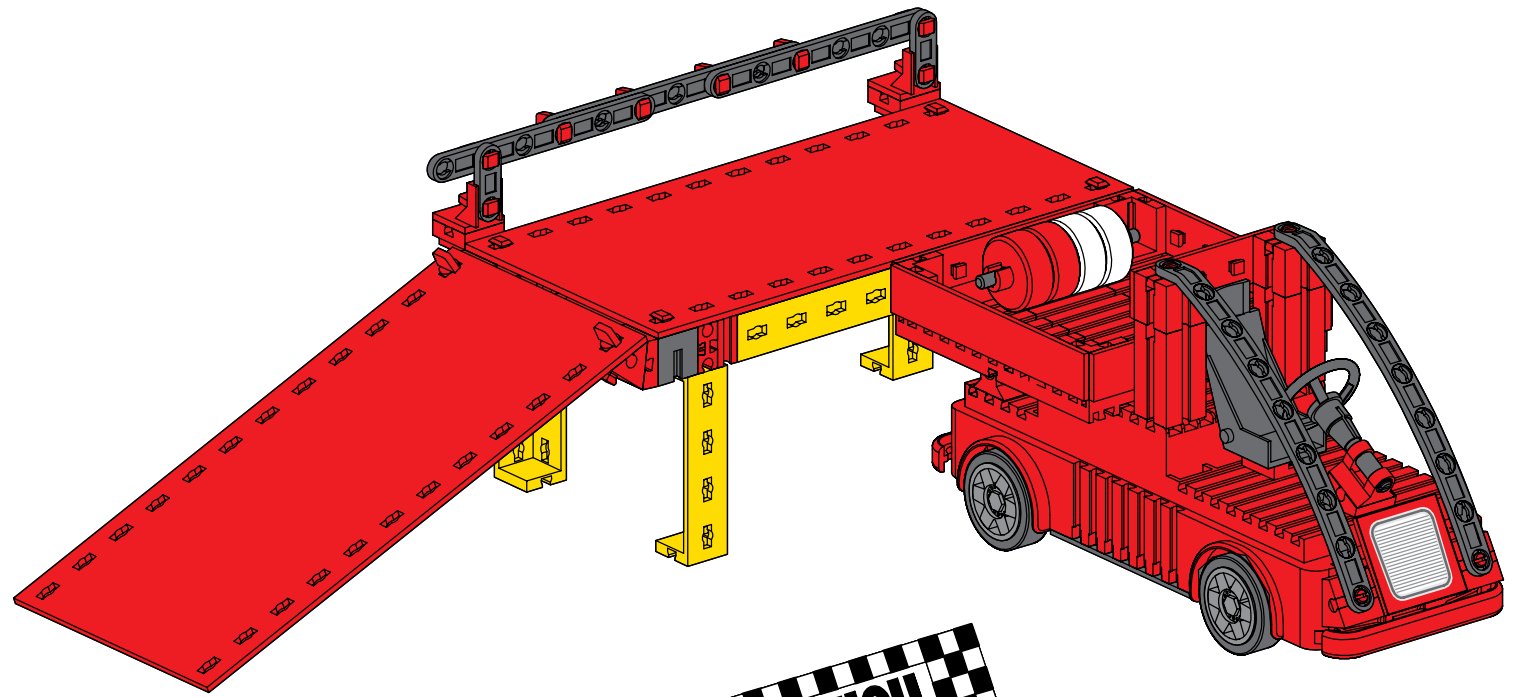
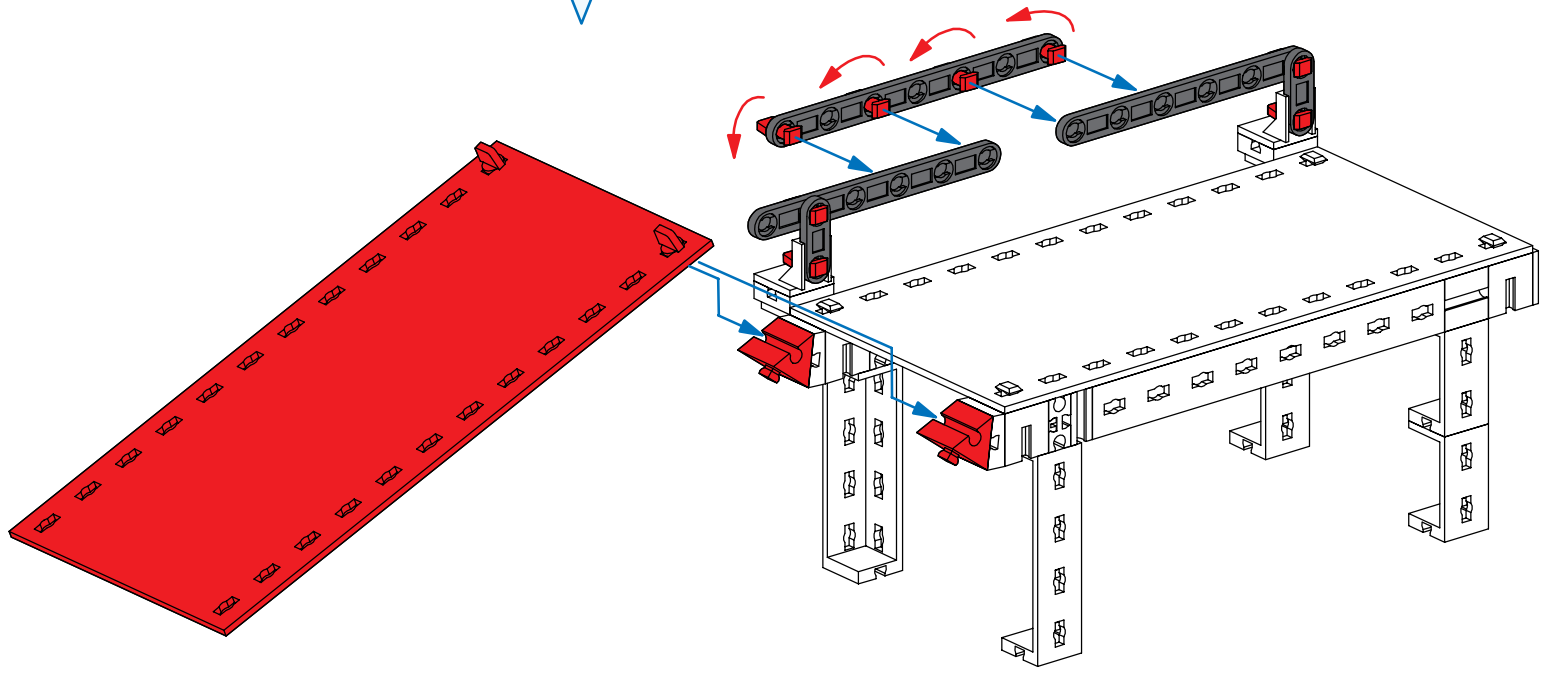
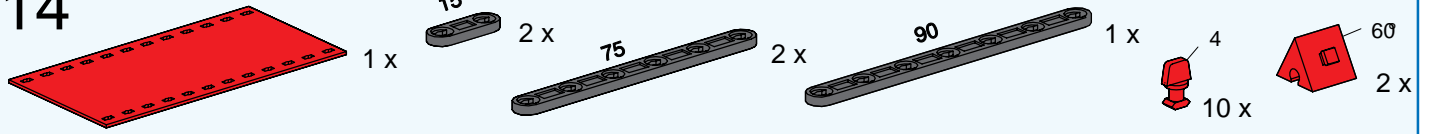

Van mit Carport
 Van with carport
 Van avec abri de voiture

Bestelwagen met carport
 Monovolumen con tejado de proteccion
 Van com estacionamento coberto

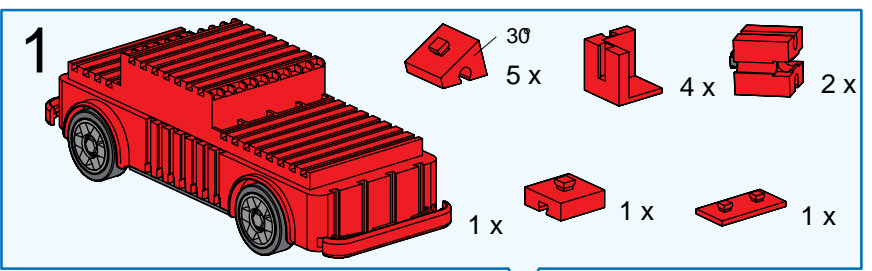

Montagetipps Seite 2
 Tips for assembly Page 2
 Tuyaux pour le montage page 2
 Montagetips zie bladzijde 2
 Consejos para el montaje, ver la página 2
 "Dicas" para montagem Página 2

