

# AUTOMOBILE

fischertechnik 

ADVANCED

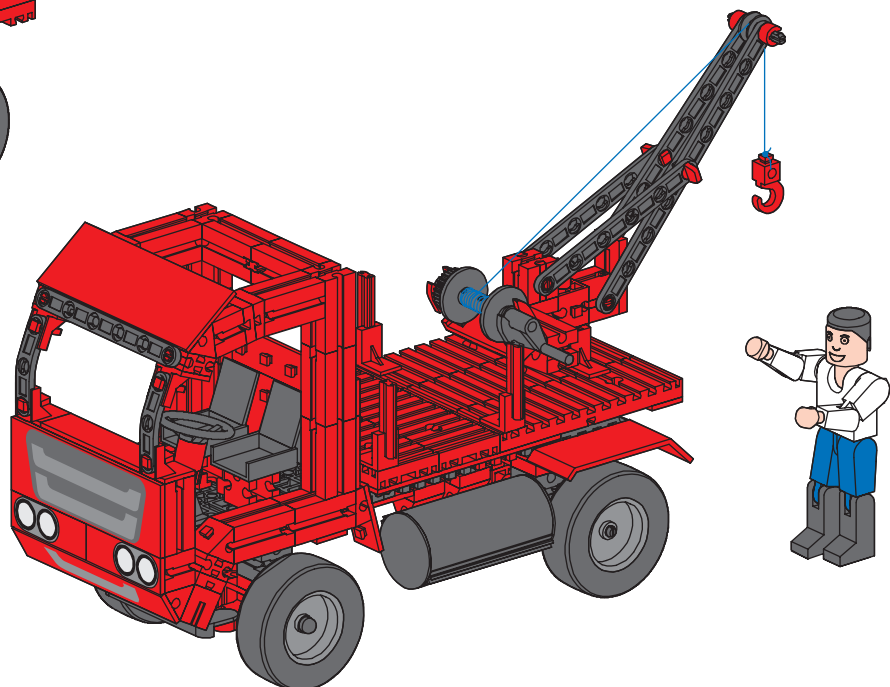

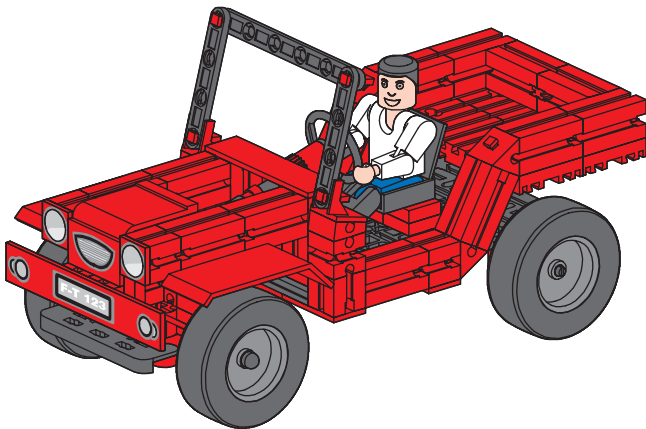
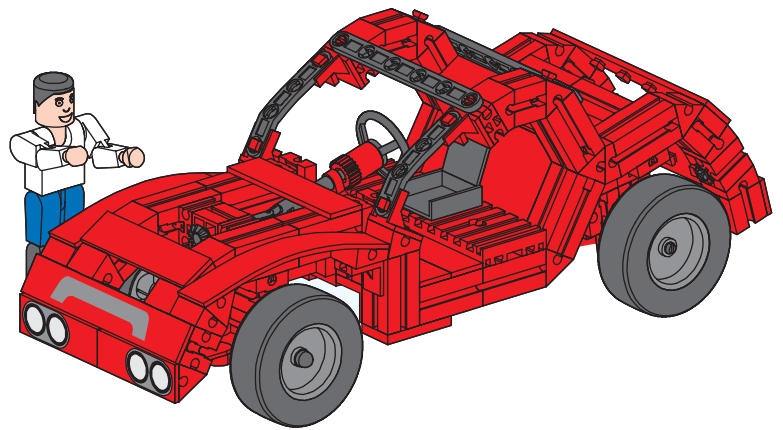
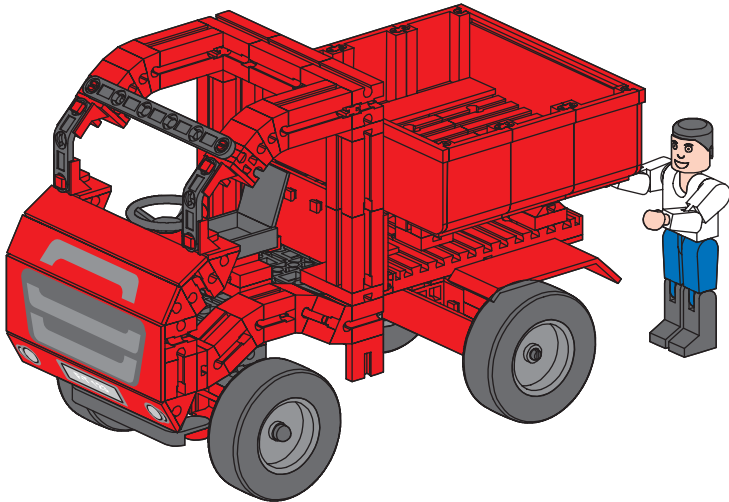







**Montagetipps**  
**Tips for assembly**  
**Tuyaux pour le montage**

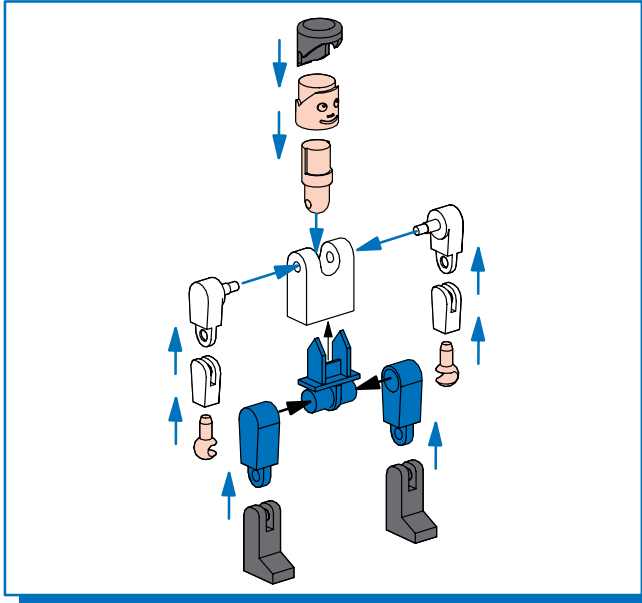

**Montagetipps**  
**Consejos para el montaje**  
**"Dicas" para montagem**

**Consigli per il montaggio**  
**Рекомендации по сборке**  
**装配建议**

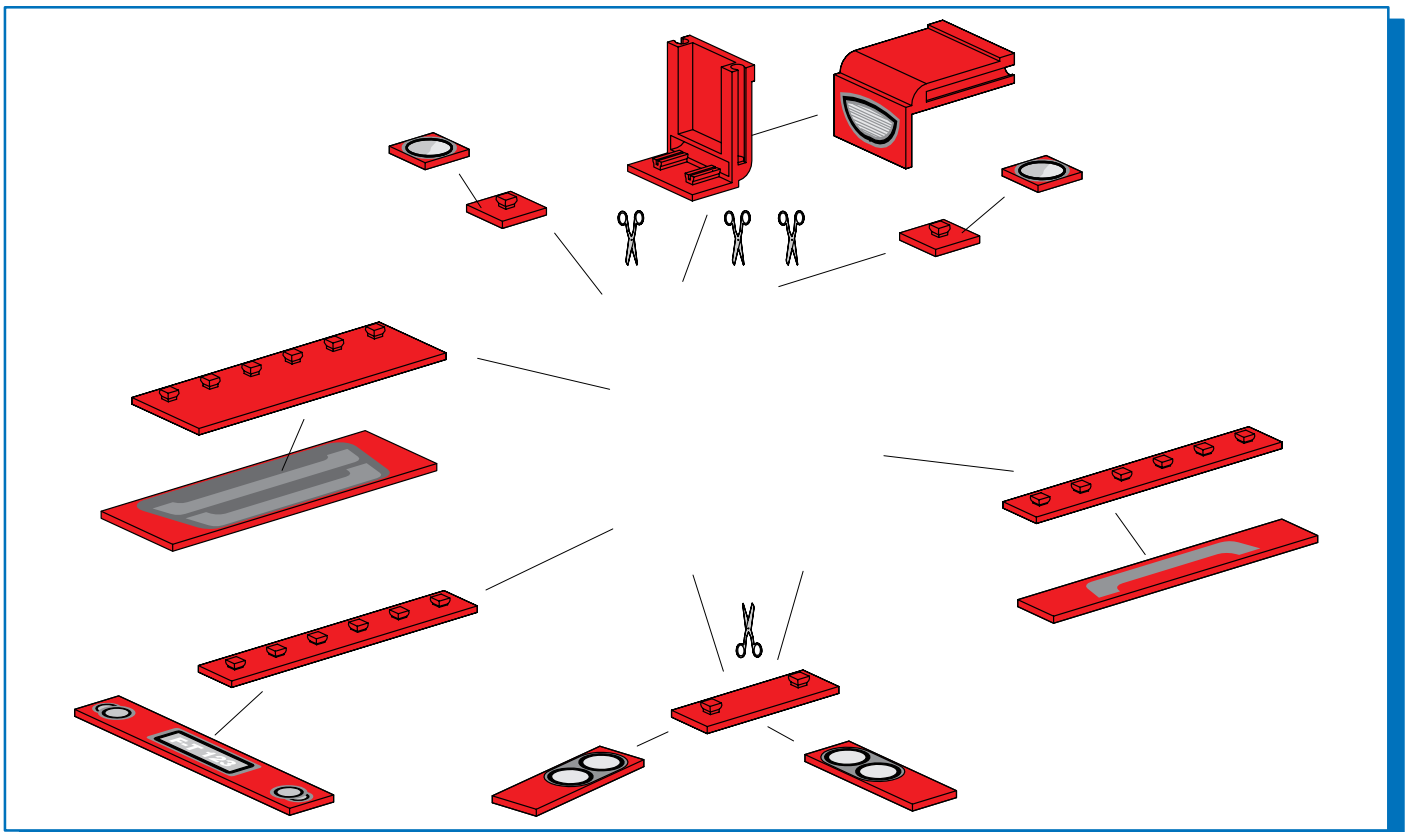
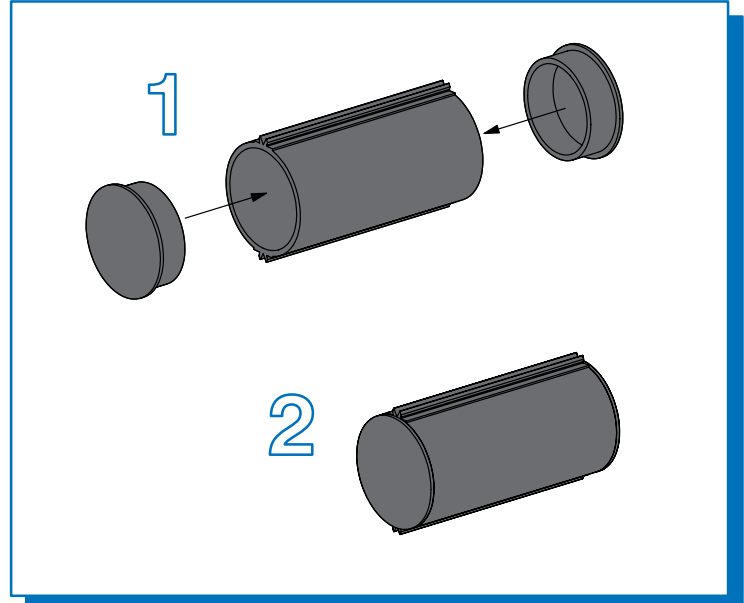

Alle Einzelteile, insbesondere bewegliche Teile sind falls notwendig zu warten und zu reinigen.  
 All components, especially moving parts, should be maintained and cleaned as necessary.  
 Toutes les pièces détachées et en particulier les pièces mobiles, sont, si nécessaire, à entretenir et à nettoyer.  
 Alle onderdelen, vooral de bewegende delen, kunnen, indien noodzakelijk, onderhouden en gereinigd worden.  
 Es necesario limpiar y mantener en buen estado todas las diferentes piezas - especialmente las piezas móviles

**Achtung**  
 Verletzungsgefahr an Bauteilen mit funktionsbedingten scharfen Kanten und Spitzen!  
**Caution**  
 Be careful not to hurt yourself on components with sharp or pointed edges!  
**Attention**  
 Risque de blessure sur les éléments comportant des arêtes et o pointes vives indispensables au bon fonctionnement!  
**Let op**  
 U kunt zich bezeren aan bouwstenen met scherpe randen of punten!  
**Attenzione**  
 Esiste il pericolo di lesione con i pezzi di costruzione che hanno bordi e punte spigolosi necessari per la funzionalità del pezzo!

Caso necessário, todas as peças individuais, especialmente peças móveis, tem que ser submetidas à manutenção e ser limpidas.  
 Se necessario, tutti i singoli componenti, soprattutto le parti mobili, si devono eventualmente sottoporre a manutenzione e pulizia.  
 Все детали конструктора, в особенности его подвижные части, необходимо содержать в исправности и очищать их по мере необходимости  
 必要时应保养和清洁所有零件，尤指运动部件。

**Atenção**  
 Perigo de ferimentos em peças componentes com cantos vivos e pontas obrigatórias para o funcionamento!  
**Attenzione**  
 Pericolo di lesioni dovute a componenti con spigoli vivi e punte per motivi funzionali!  
**Внимание!**  
 Во избежание травм, будьте внимательны при обращении с острыми деталями!  
**注意**  
 因功能需要而带有锋利的棱边和尖角的部件可能会带来受伤危险!

































































































































