











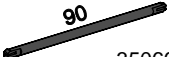





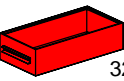



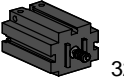

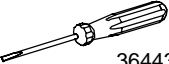

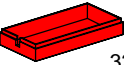

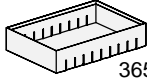











Mini Motor Set

Einzelteilübersicht
Spare parts list
Liste des pièces détachées

Onderdelenoverzicht
Lista da piezas
Lista dei pezzi

 31063	1x	 31982	10x	 90 35066	1x	 35983	1x
 31078	1x	 32233	1x	 35069	1x	 36227	1x
 31082	1x	 32263	1x	 35070	1x	 36382	1x
 31336	3x	 32293	1x	 35072	1x	 36443	1x
 31337	3x	 32958	1x	 35073	2x	 36587	1x
 31411	1x	 35061	2x	 75 35087	1x	 36588	1x
 31412	2	 35062	2x	 35945	2x	 36708	1x
 31413	2x	 30 35063	2x	 35971	2x	 37468	2x
 31414	1x	 45 35064	3x	 35972	1x	 37858	1x
 31915	1x	 60 35065	1x	 35982	1x		

Alle Einzelteile, insbesondere bewegliche Teile sind falls notwendig zu warten und zu reinigen.

All components, especially moving parts, should be maintained and cleaned as necessary.

Toutes les pièces détachées et en particulier les pièces mobiles, sont, si nécessaire, à entretenir et à nettoyer.

Alle onderdelen, vooral de bewegende delen, kunnen, indien noodzakelijk, onderhouden en gereinigd worden.

Es necesario limpiar y mantener en buen estado todas las diferentes piezas – especialmente las piezas móviles.

Provvedere all'occorrenza alla manutenzione e alla pulizia di tutti i particolari, specialmente le parti mobili.

Achtung

Verletzungsgefahr an Bauteilen mit funktionsbedingten scharfen Kanten und Spitzen!

Caution

Be careful not to hurt yourself on components with sharp or pointed edges!

Attention

Risque de blessure sur les éléments comportant des arêtes et pointes vives indispensables au bon fonctionnement!

Let op

U kunt zich bezeren aan bouwstenen met scherpe randen of punten!

Attenzione

Esiste il pericolo di lesione con i pezzi di costruzione che hanno bordi e punte spigolosi necessari per la funzionalità del pezzo!

Precaución

Peligro de heridas ocasionadas por componentes puntiagudos o de cantos afilados que estén en funcionamiento!

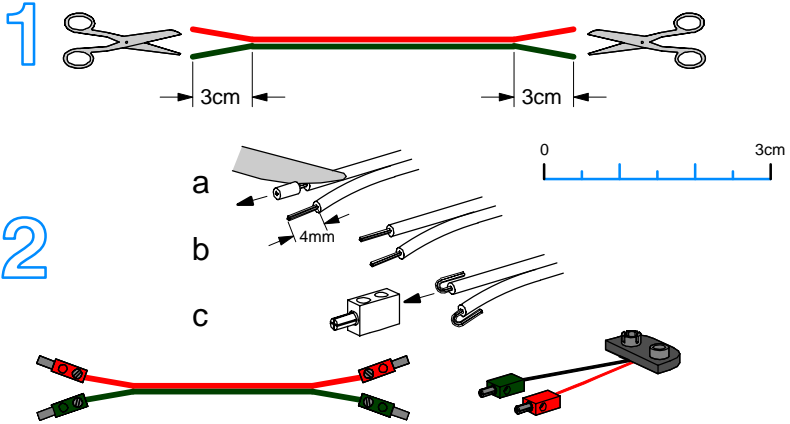

Batterie ist nicht Inhalt der Packung
Battery not included
Batterie non comprise
De batterij wordt niet meegeleverd
La batteria non è compresa
La batería no está incluida en el suministro

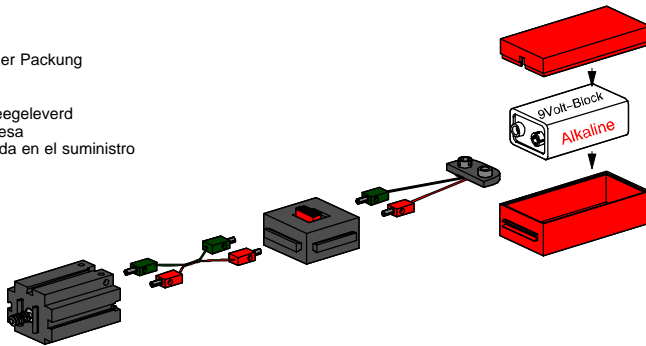

1 Batterie 9Volt-Block Alkaline oder 1 NC-Akku 9V

- Leere Akkus zum Laden entnehmen.
- Verbrauchte Batterien dem Sondermüll zuführen.

9V rechargeable battery or 9 V alkaline dry cell

- Remove discharged battery and place in charger for recharging.
- Discard spent dry cells at special waste disposal centre.

pila 9V ou accu 9V

- Pour recharger les accus vides, il faut les sortir et les placer dans le chargeur.
- Jeter les piles usagées dans un conteneur spécial réservé à cet effet.

alkaline batterije of oplaadbare batterije (9Volt)

- Voor het opladen van batterijen de lege batterijen uit nemen en met behulp van het oplaadapparaat opladen.
- Aflleveren gebruikte batterijen bij het klein chemisch afval (KCA).

batteria normale o batteria ad accumulatore (9Volt)

- Togliere le batterie ad accumulatore scariche per ricaricarle.
- Gettare le batterie scariche negli appositi cassonetti di raccolta differenziata.

pila alcalina bloque de 9 Voltios o acumulador NC de 9 Voltios

- Retirar el acumulador descargado y colocarlo en el cargador
- Retirar las baterías viejas, desechándolas en un depósito de basuras especiales.



oder
or
ou
of
o

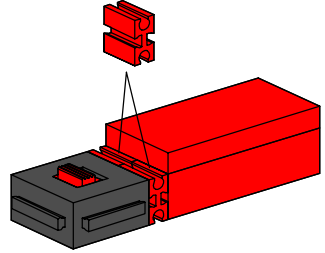
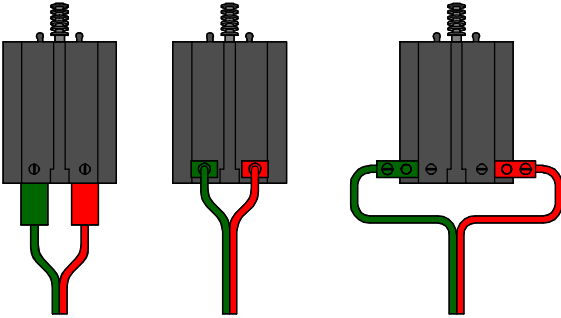
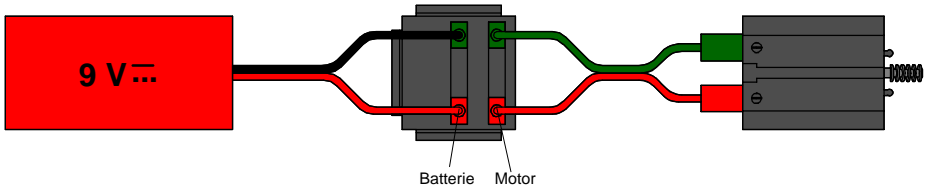

Montagen
Mountings
Montages

Montage's
Montajes
Assemblaggio

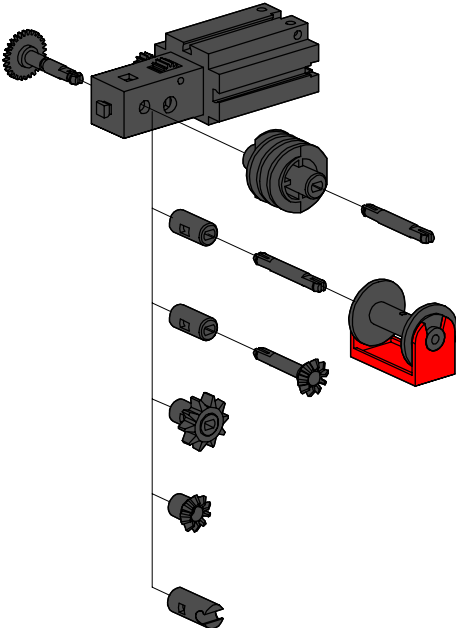

1

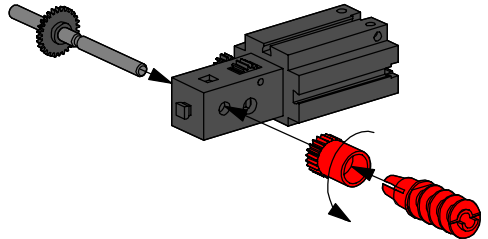

2

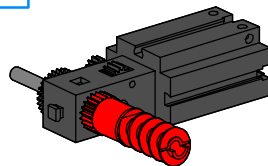

1

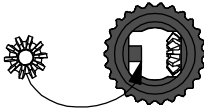

2

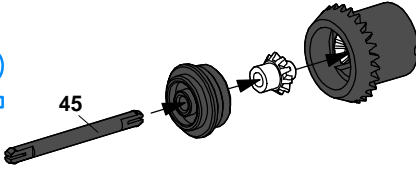

3

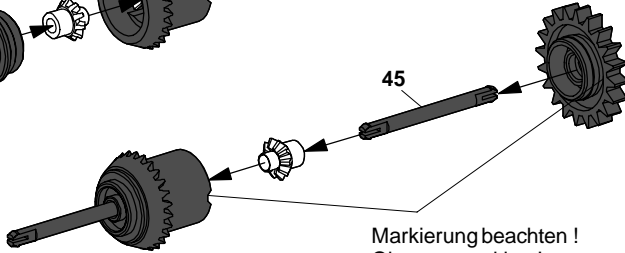

Markierung beachten !
Observe marking !
Attention au marquage !
Let op markering !
Tener en cuenta la marcación !
Osservare la marcatura !

4

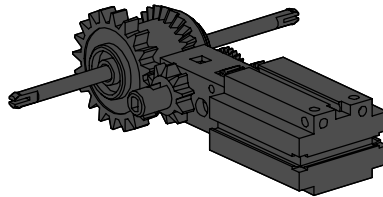
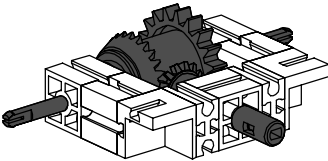
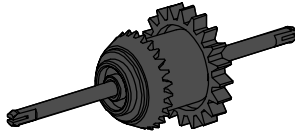

1

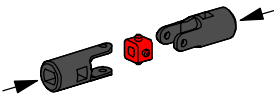

2

