

Teleskop-Mobilkran  
Heavy duty crane truck  
Grue télescopique mobile  
Teleskoopkraanwagen  
Camión grúa telescópica  
Gru telescopica semovente  
Teleskop-Mobilkran









**Funkfernsteuerungs-Set**

Einbau der Fernsteuerung in das motorisierte Modell Seite 40-47.

**Radio control set**

Installation of the remote control in the motorized model Page 40-47.

**Poste radio de télécommandes**

Montage de la télécommande sur le modèle motorisé. Pages 40-47

**Set voor draadloze besturing**

Montage van de afstandbediening in het gemotoriseerde model op blz. 40-47.

**Estuche de radiotelemando**

Montaje del control remoto en el modelo motorizado. Páginas 40-47.

**Impianto di radiotelecomando**

Montaggio del telecomando nel modello a motore. Pagina 40-47

**Radiofjärrstyrningsset**

Fjärrstyrningens inmontering i den motoriserade modellen sidorna 40-47.

**Empfänger 2**

Fernsteuern der Kranfunktionen Seite 48-52.

**Receiver 2**

Remote control of the crane functions. Page 48-52

**Récepteur 2**

Télécommande des fonctions de la grue. Pages 48-52

**Ontvanger 2**

Afstandbediening van de kraanfuncties op blz. 48-52.

**Receptor 2**

Dirección a distancia de las funciones de la grúa. Páginas 48-52

**Ricevente 2**

Telecomando delle funzioni della gru. Pagina 48-52

**Mottagare 2**

Fjärrstyrning av kranfunktionerna sidorna 48-52.



1

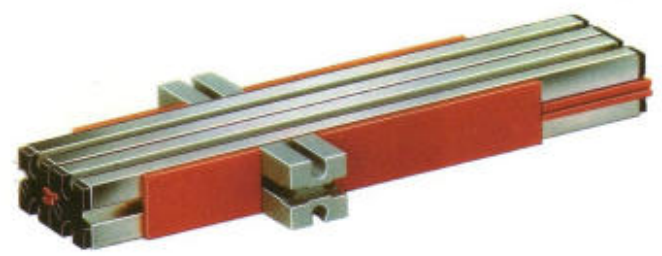
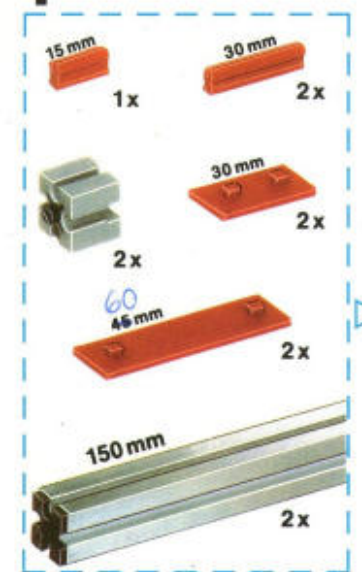

3

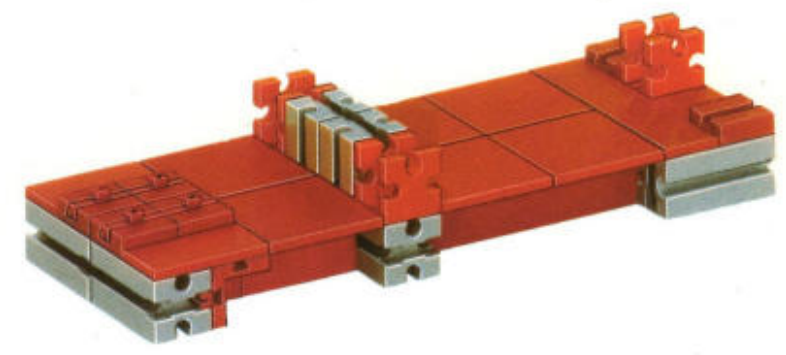
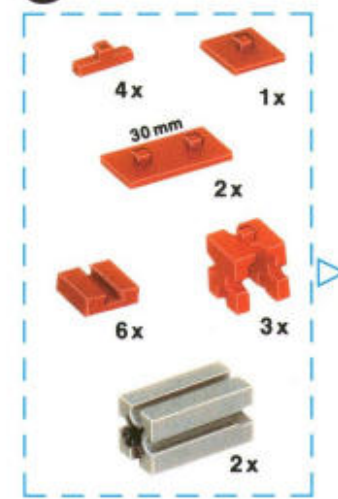

2

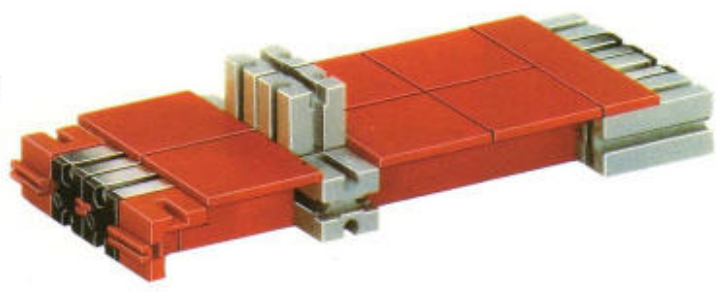
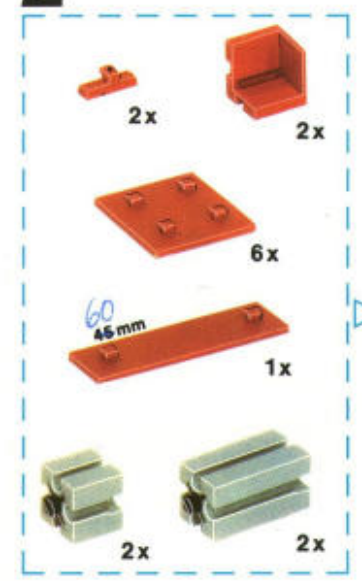

4

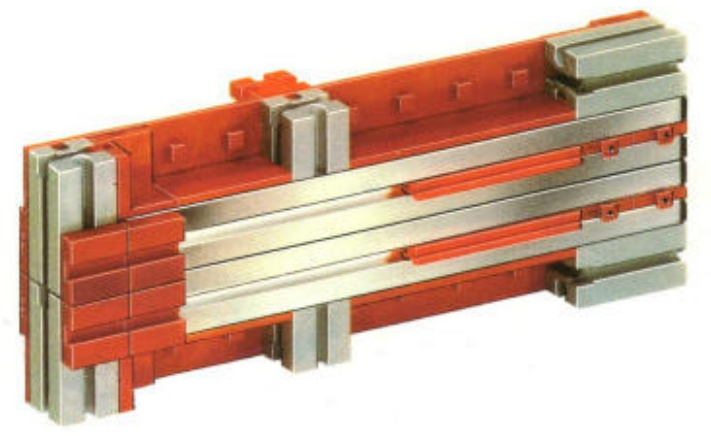
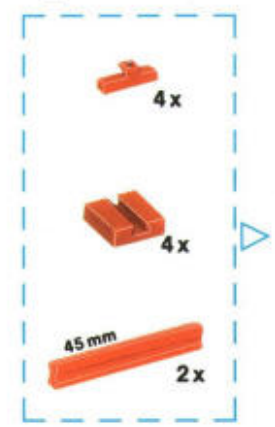



5

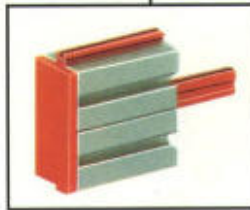
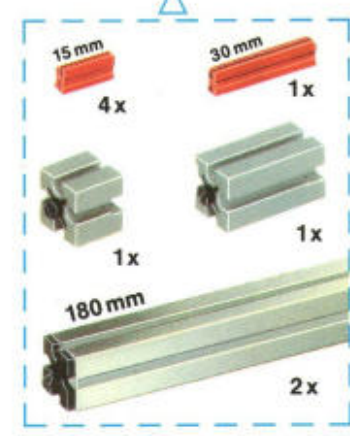
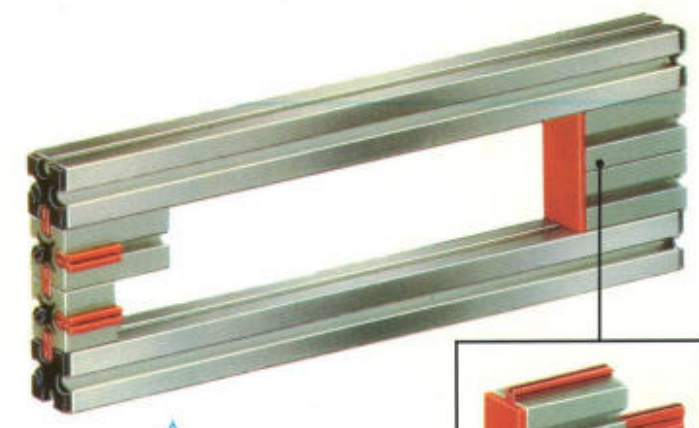
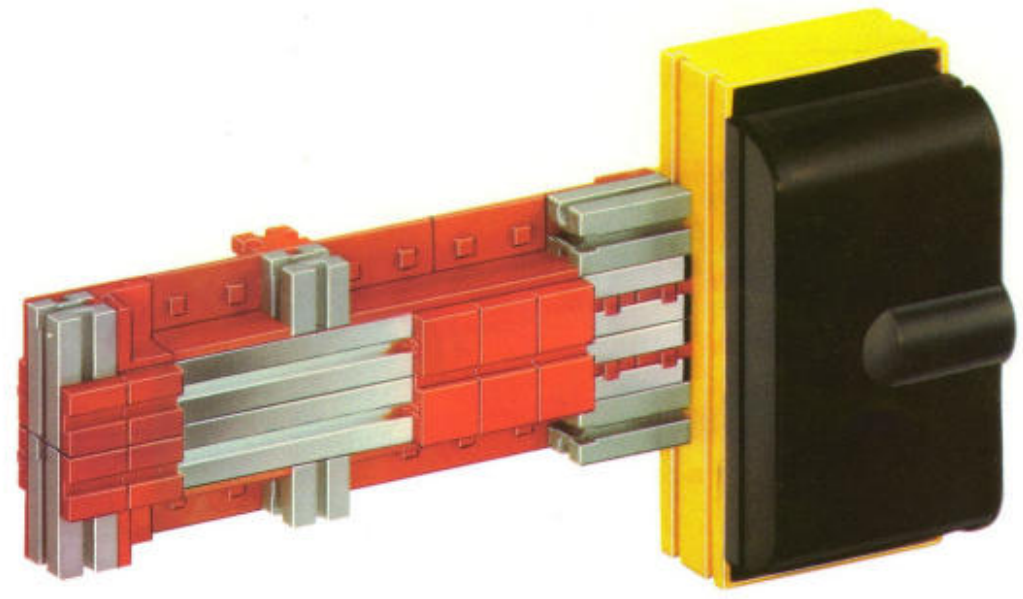

6

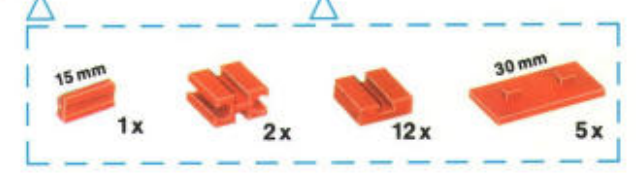
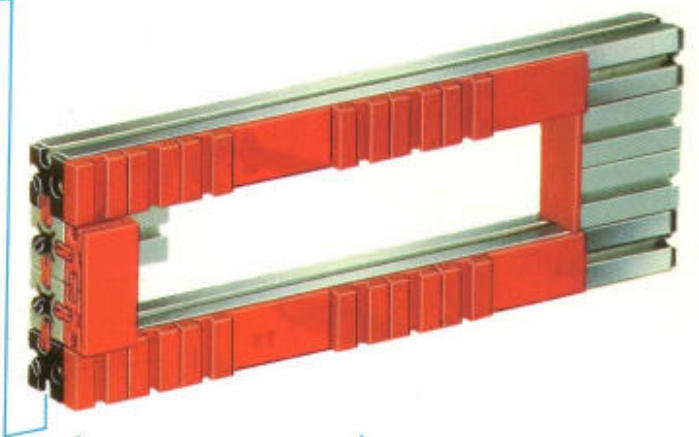
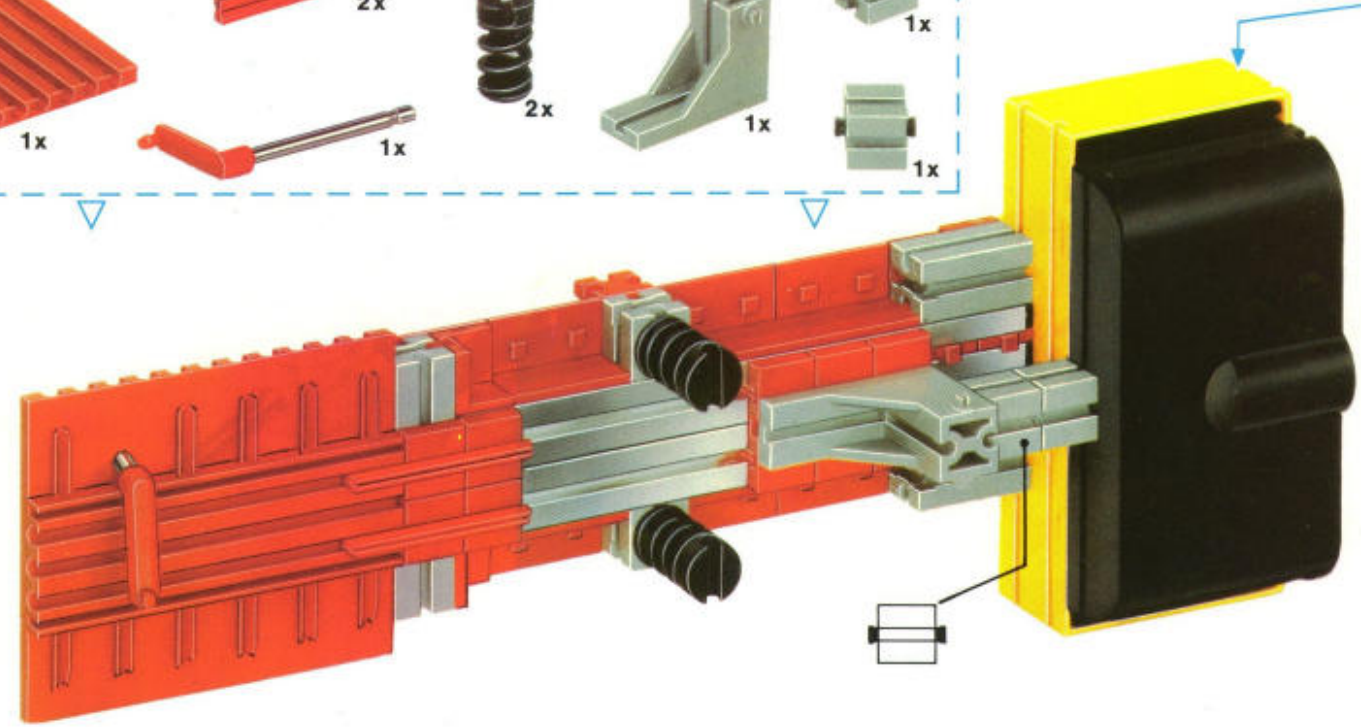
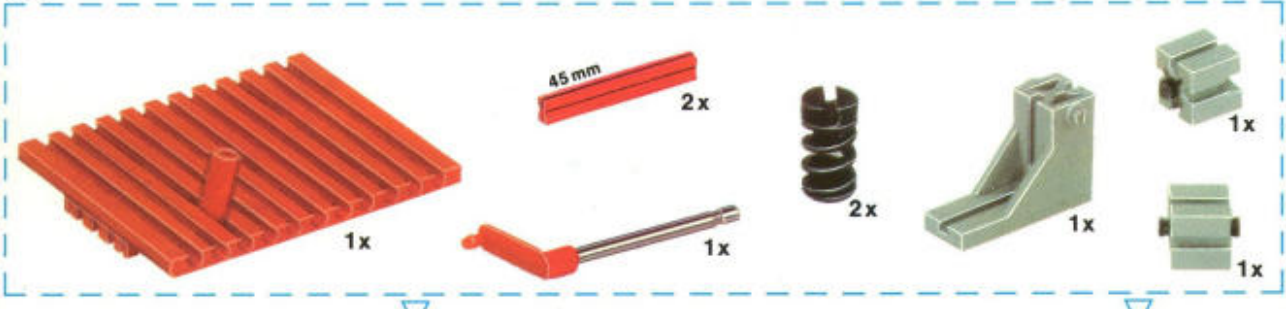

7

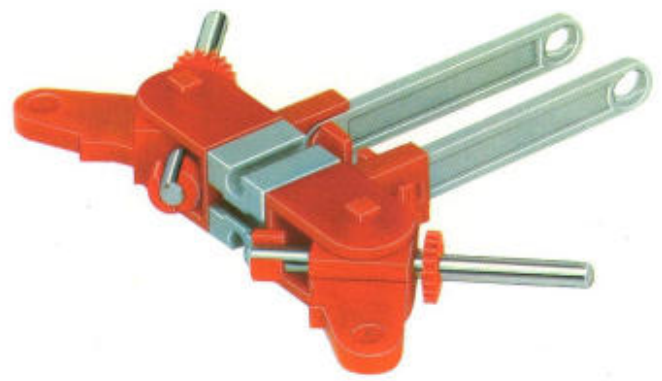
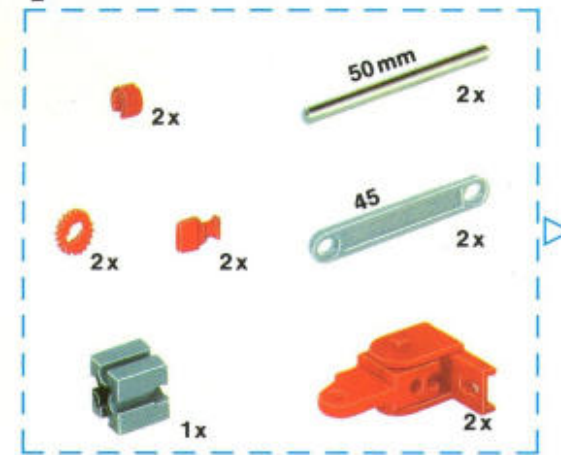

8

