

fischertechnik® 

„ DIE DAMPFWALZE „
um 1920

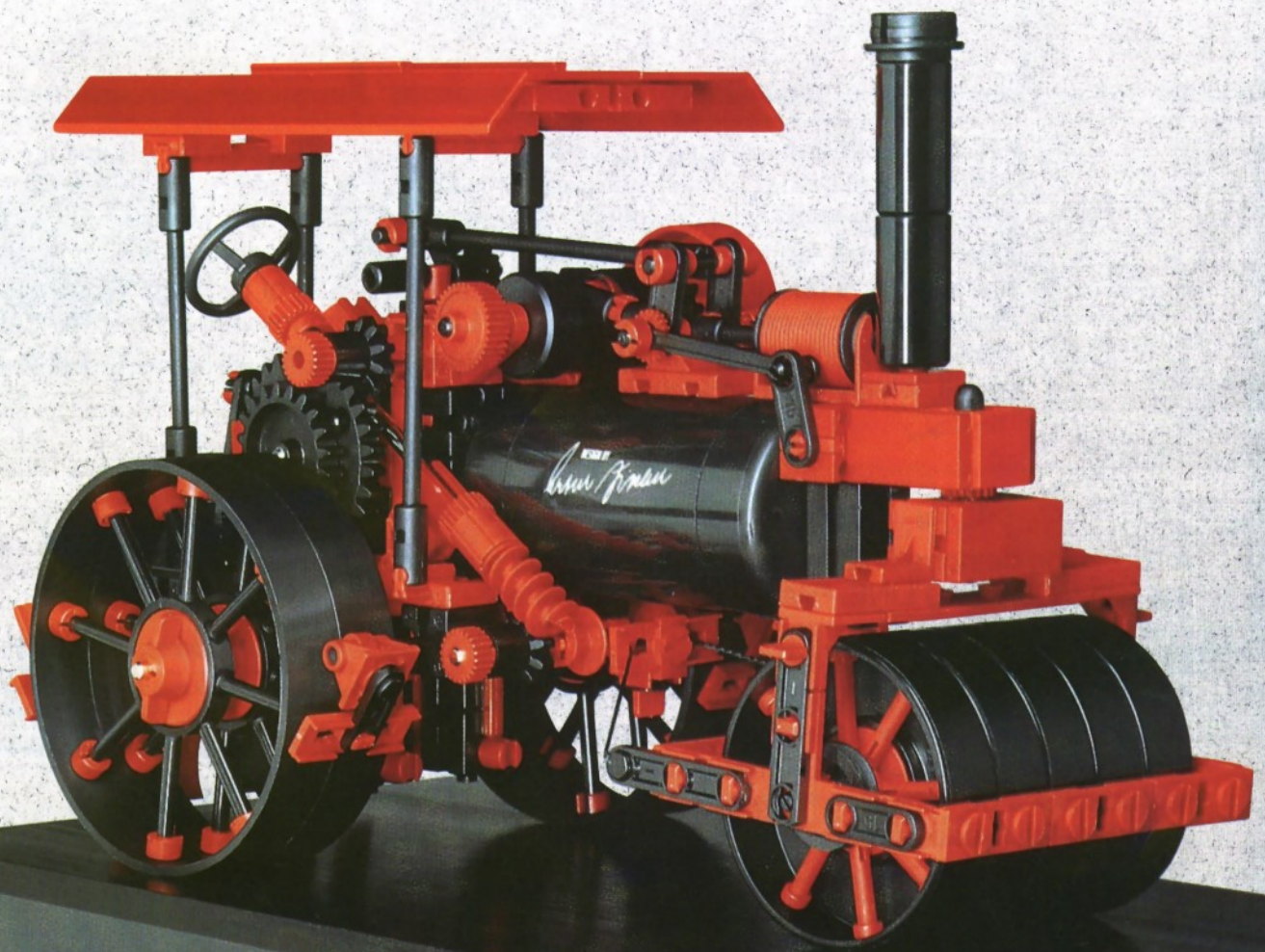













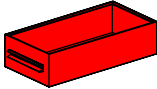



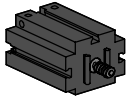
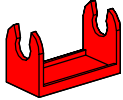



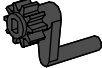
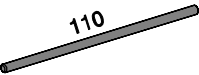

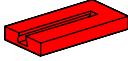







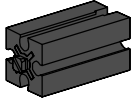
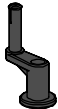

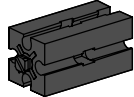

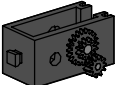









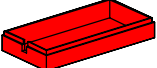
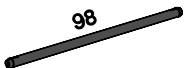







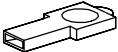

CLASSIC LINE

Design by

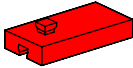
Karl Fischer

Einzelteilübersicht

Spare parts list Liste des pièces détachée Onderdelenoverzicht

	31020 1x		31670 5x		32263 1x		35065 3x
	31022 1x		31672 2x		32293 1x		35069 1x
	31023 3x		31674 2x		32316 9x		35071 1x
	31031 1x		31690 16x		32330 4x		35073 1x
	31058 10x		31731 2x		32870 1x		35087 3x
	31060 7x		31772 4x		32879 9x		35088 1x
	31061 10x		31848 5x		32880 2x		35112 2x
	31078 1x		31915 2x		32881 14x		35113 2x
	31082 1x		31916 1x		32882 9x		35386 1x
	31124 1x		31982 11x		32958 1x		35414 1x
	31330 4x		31983 1x		32973 2x		35797 2x
	31436 7x		31999 1x		35016 2x		35799 1x
	31592 5x		32064 5x		35031 10x		35945 1x
	31597 8x		32071 2x		35049 4x		35971 2x
	31667 11x		32233 1x		35063 1x		35972 1x

