

PROFI CARTTECH



18
models

fischertechnik[®]



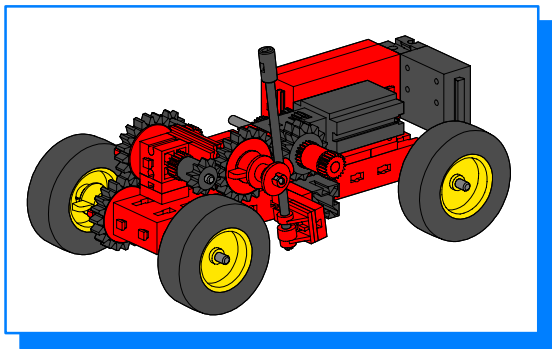

Fahrzeug mit Schaltgetriebe
 Vehicle with gear shifting
 Véhicule à boîte de vitesses

Voertuig met versnellingsbak
 Vehículo con cambio de marcha
 Veículo com caixa de câmbio

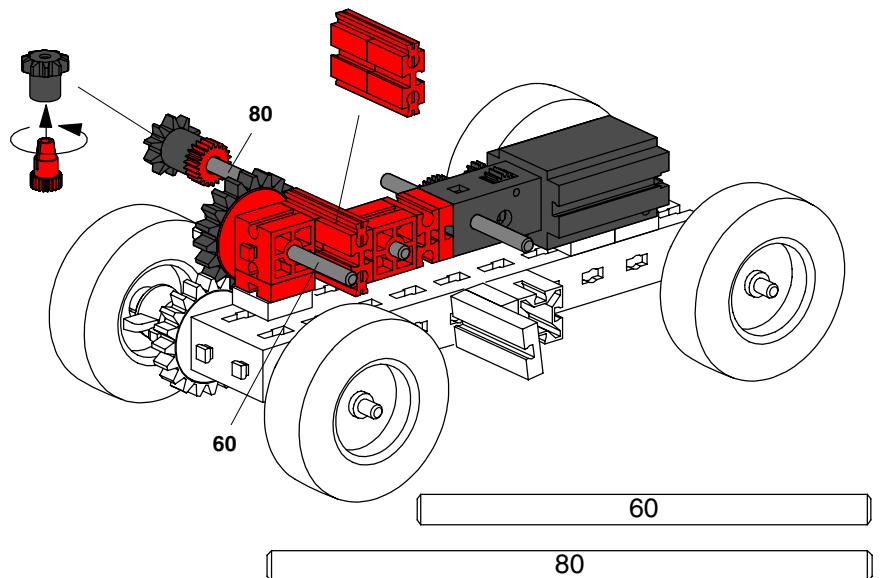
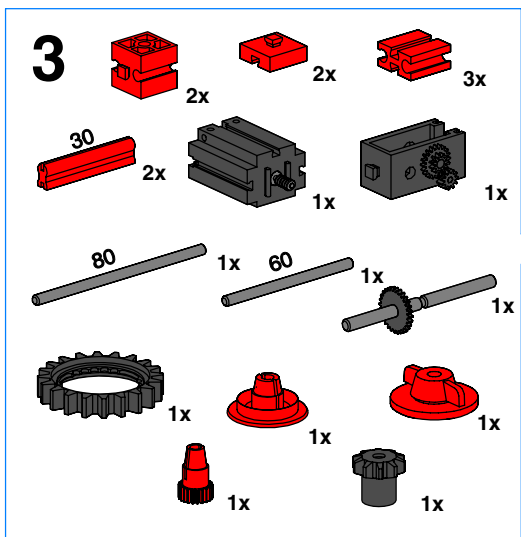
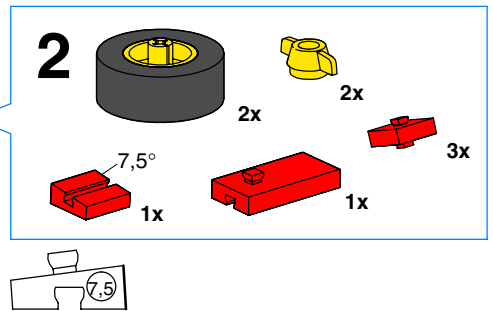
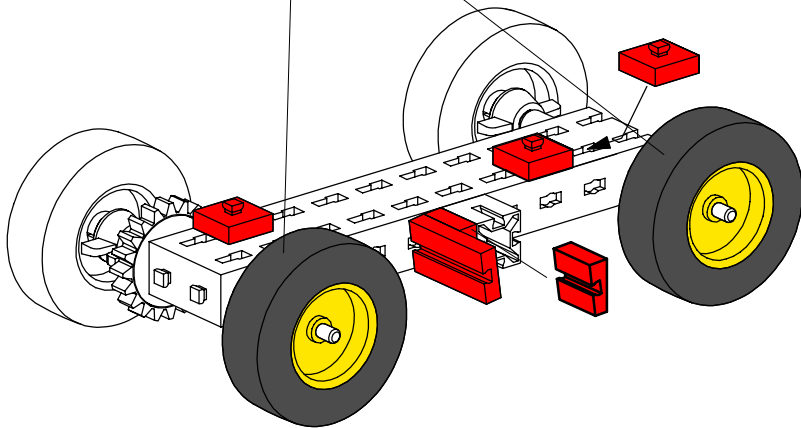
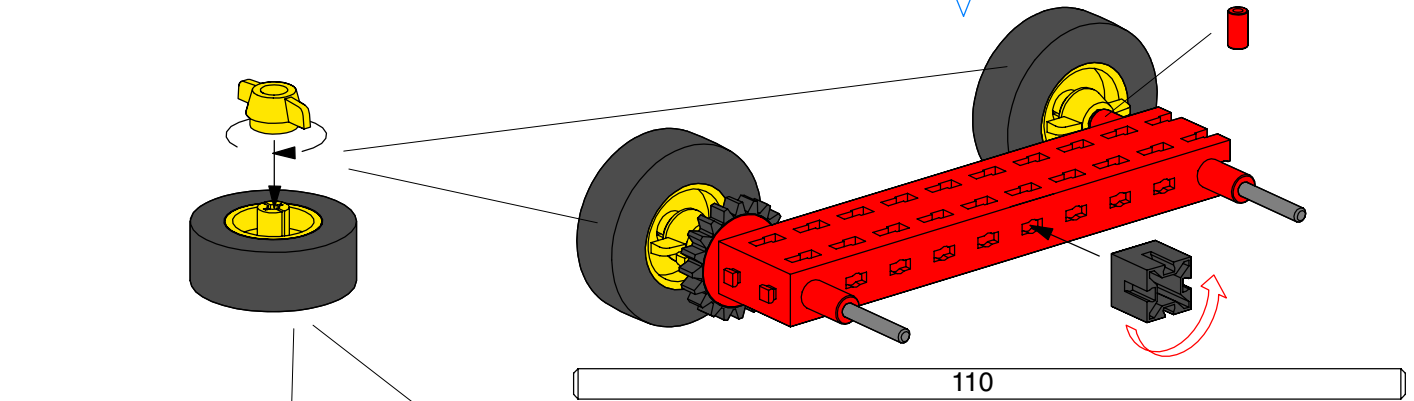
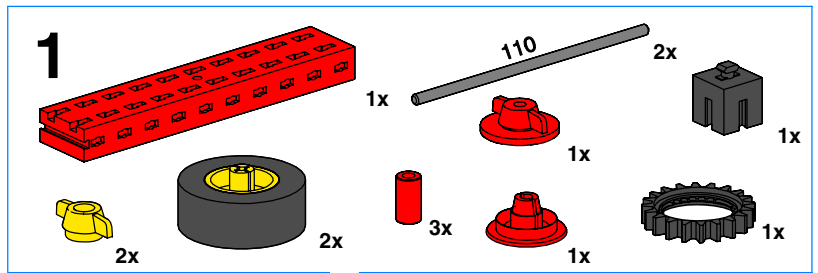

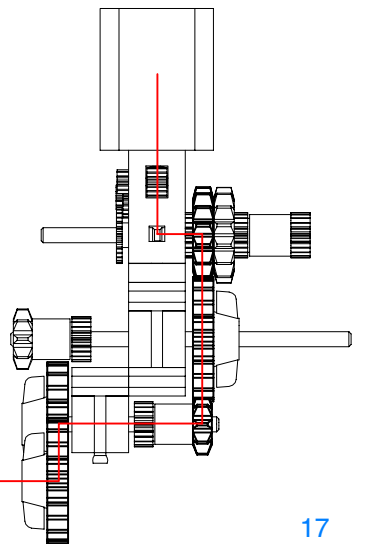
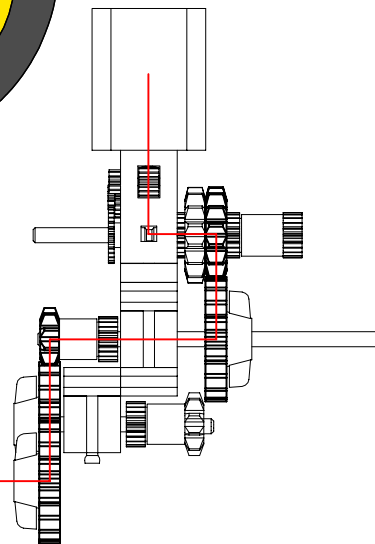
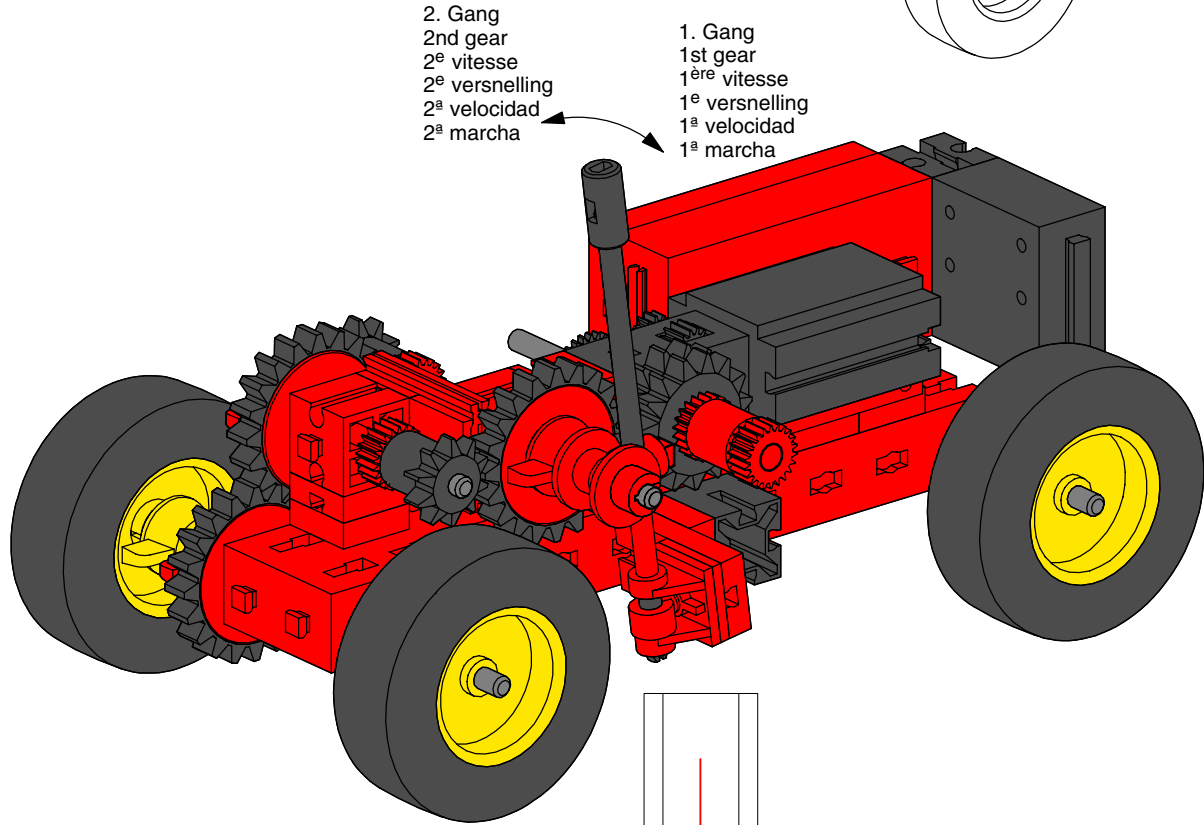
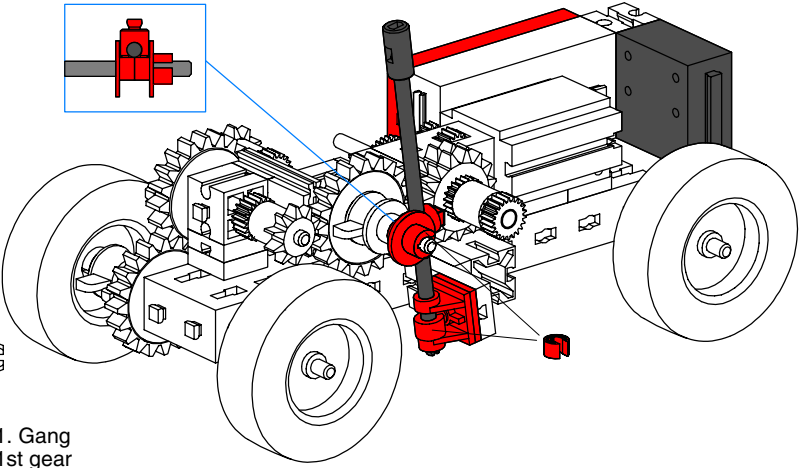
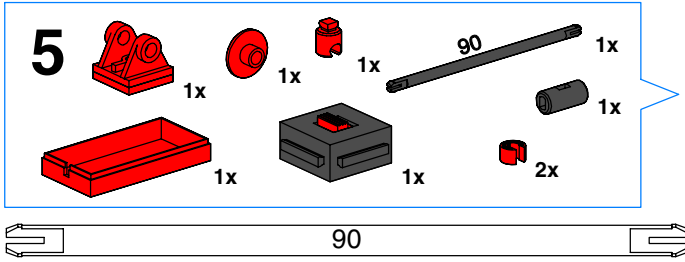
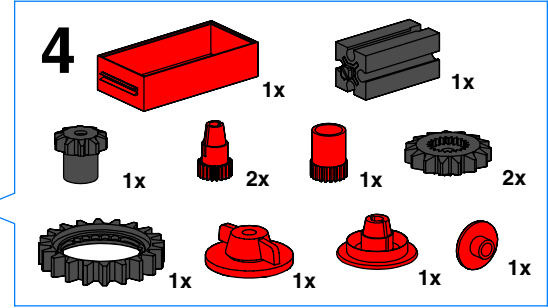
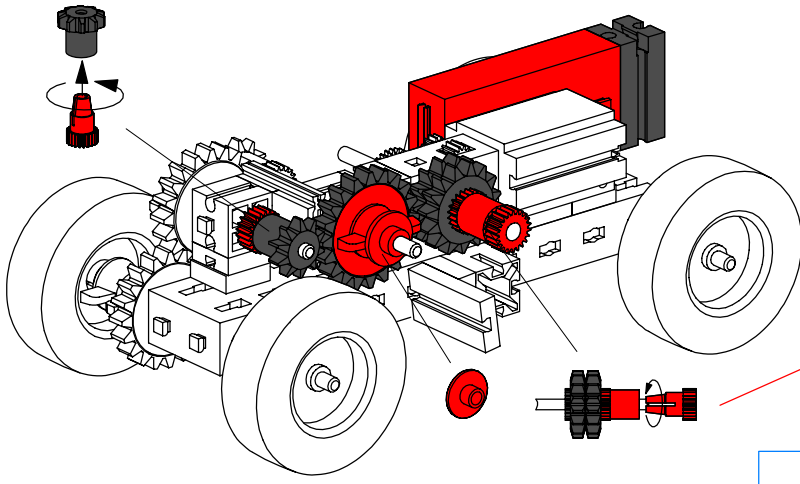

Schaltgetriebe mit
Rückwärtsgang
Gear shifting with
reverse gear
Boîte de vitesses à
marche arrière

Versnellingsbak met
achteruit versnelling
Cambio de marcha con
marcha de reversa
Caixa de câmbio com
marcha à ré

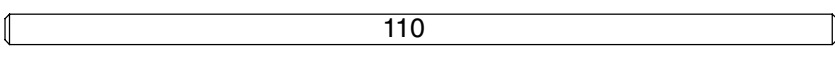
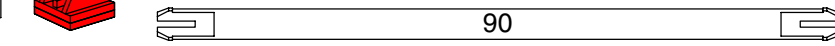
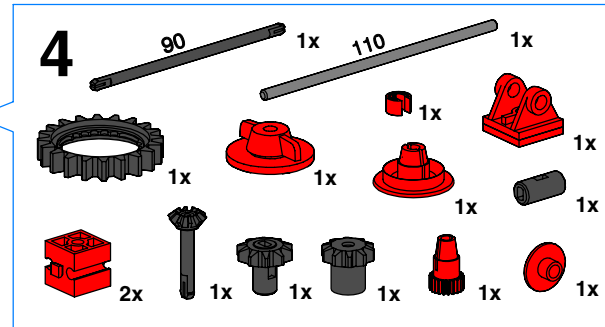
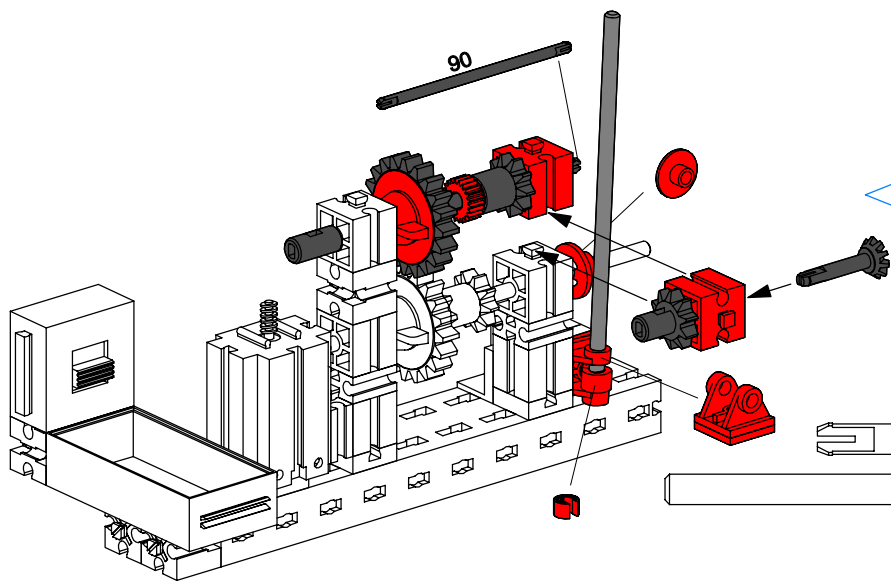
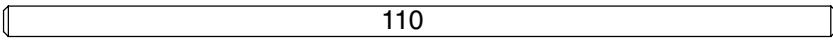
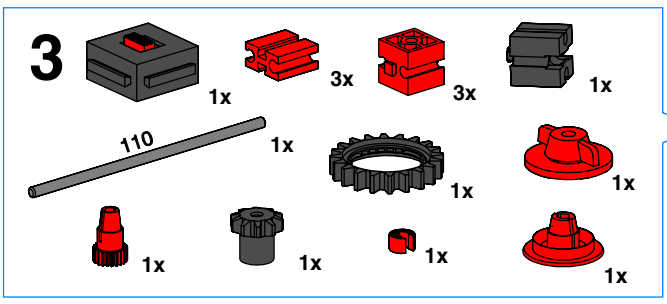
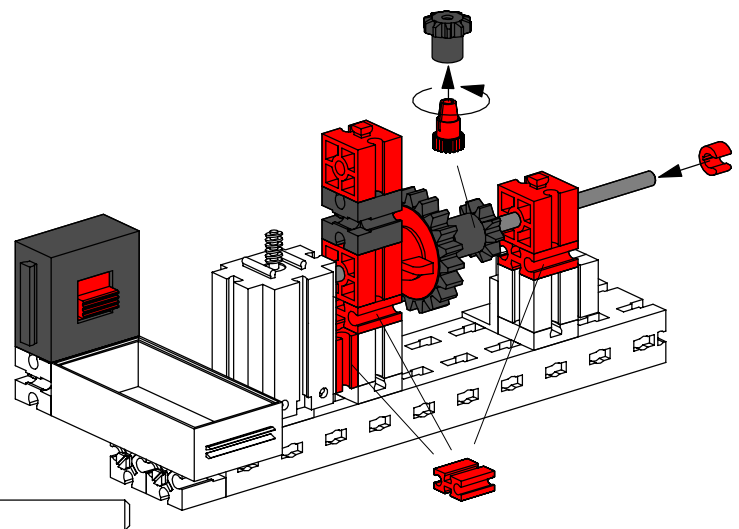
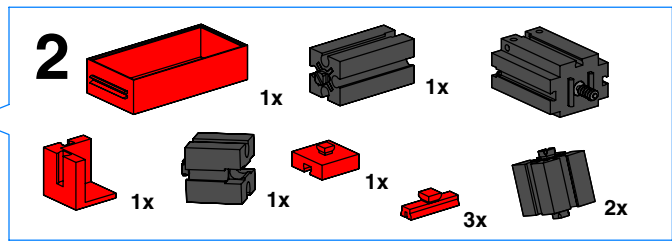
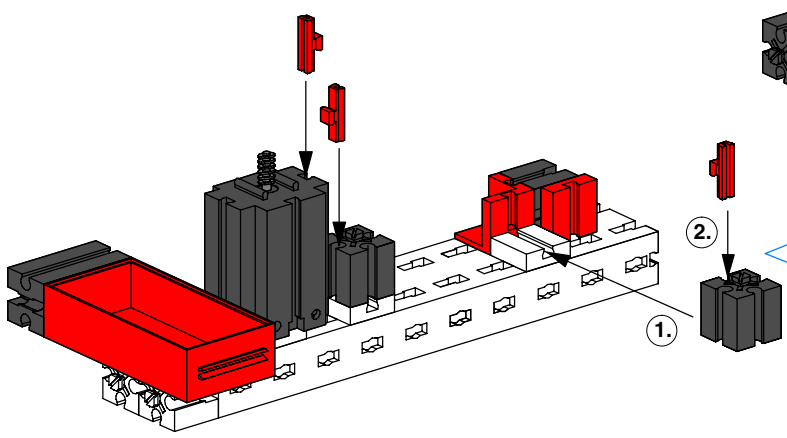
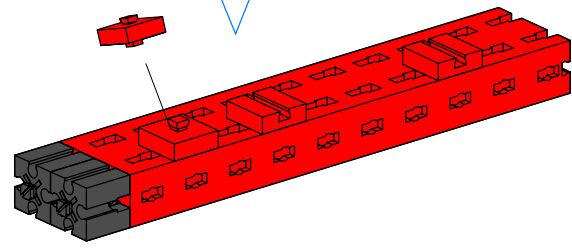
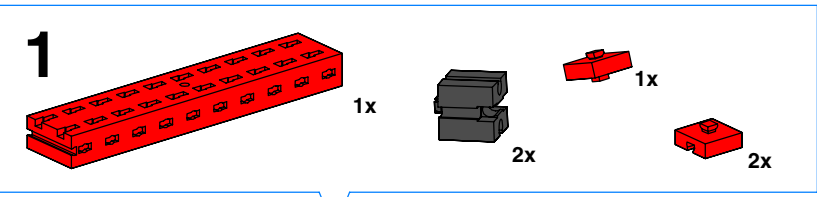
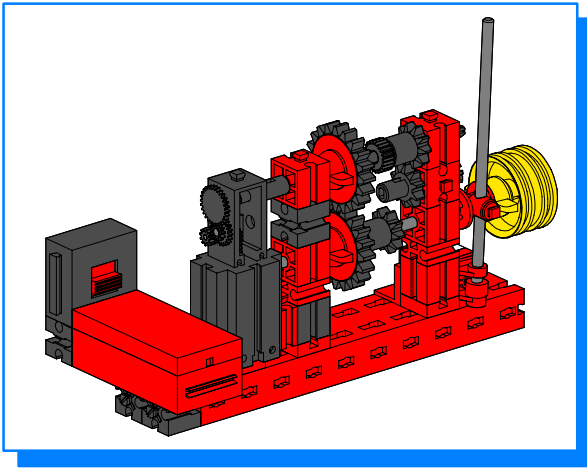

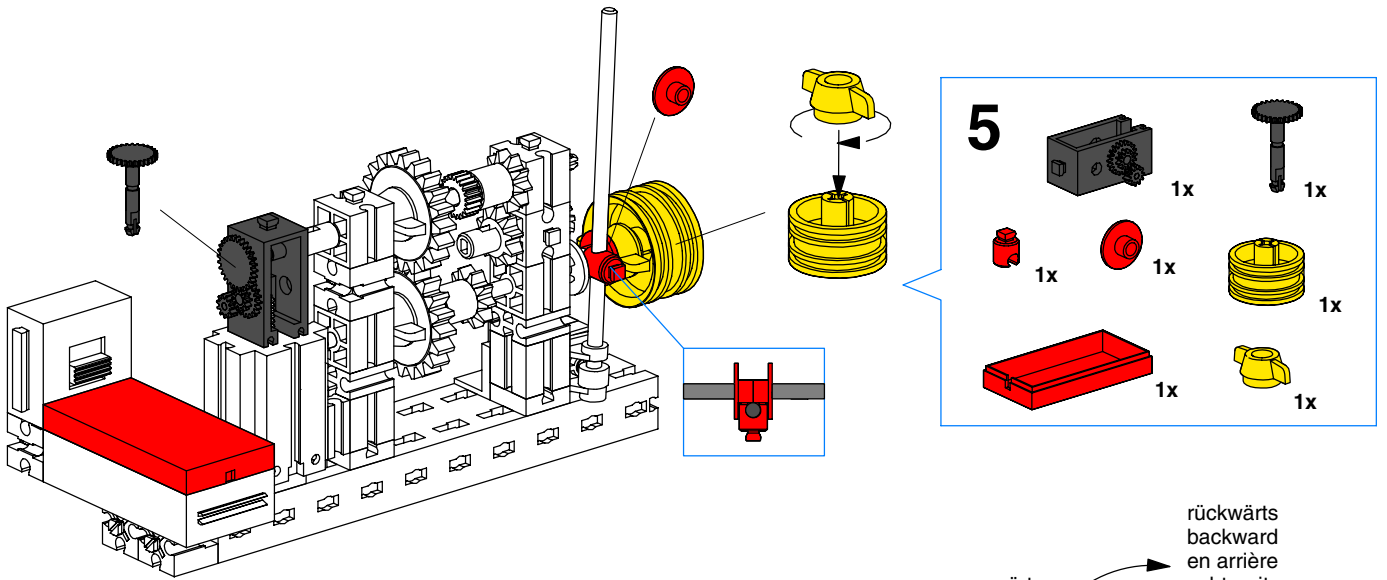

vorwärts
 forward
 en avant
 vooruit
 adelante
 para frente

rückwärts
 backward
 en arrière
 achteruit
 atrás
 para a ré

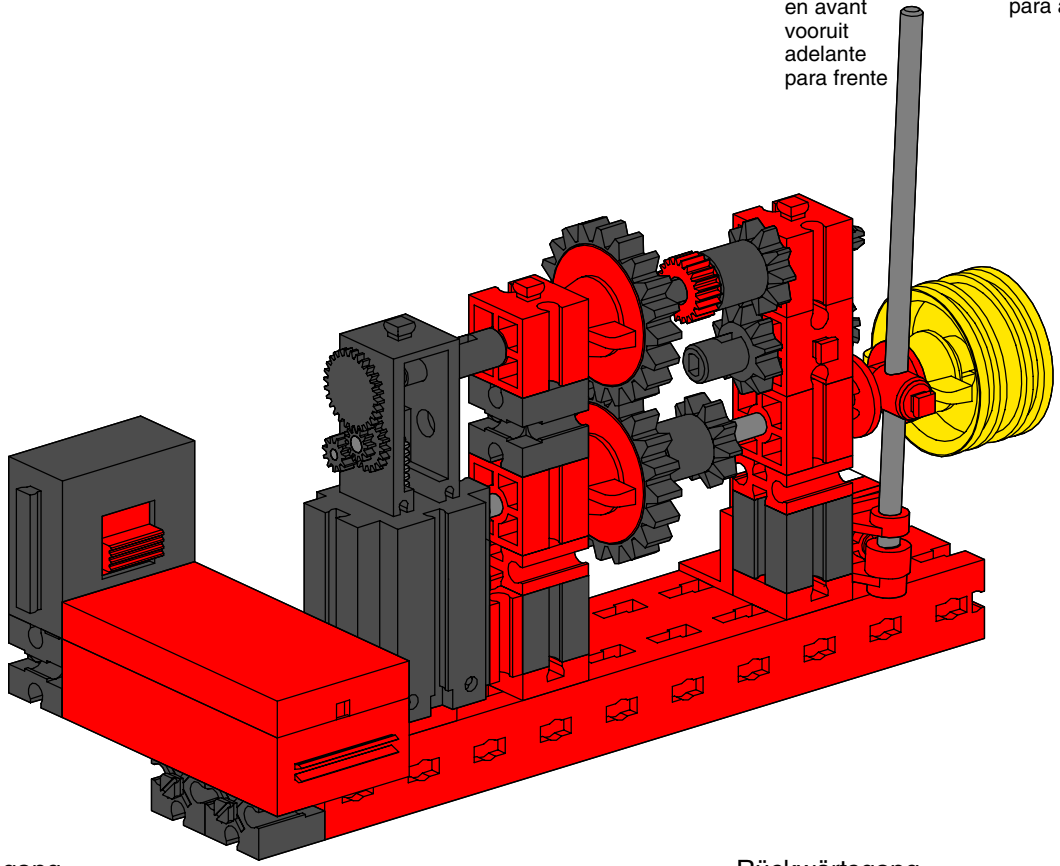

Vorwärtsgang
 Forward gear
 Marche avant
 Vooruitversnelling
 Marcha hacia adelante
 Marcha para a frente

Rückwärtsgang
 Reverse gear
 Marche arrière
 Achteruitversnelling
 Marcha de reversa
 Marcha à ré

